



# 3M-Matic™

## Instructions and Parts List

**110a** Type 10500

# Adjustable Case Sealer

with

# AccuGlide™ 2+ Taping Heads

Serial No. \_\_\_\_\_  
For reference, record machine serial number here.



**3M Industrial Adhesives and Tapes**

3M Center, Building 220-5E-06  
St. Paul, MN 55144-1000



### Important Safety Information

BEFORE INSTALLING OR  
OPERATING THIS  
EQUIPMENT

Read, understand, and follow  
all safety and operating  
instructions.

### Spare Parts

It is recommended you  
immediately order the spare  
parts listed in the "Spare  
Parts/Service Information"  
section. These parts are  
expected to wear through  
normal use, and should be  
kept on hand to minimize  
production delays.

3M-Matic™ and AccuGlide™ are Trademarks  
of 3M, St. Paul, MN 55144-1000

Printed in U.S.A.

© 3M 2005 44-0009-2035-3 (A)

## To Our Customers:

**This is the 3M-Matic™/AccuGlide™/Scotch® equipment you ordered. It has been set up and tested in the factory with Scotch® tapes. If technical assistance or replacement parts are needed, call or fax the appropriate number listed below.**

**Included with each machine is an Instructions and Parts List manual.**

### Technical Assistance:

3M-Matic™ Helpline – 1-800/328 1390. Please provide the customer support coordinator with the machine number, machine type/model and serial number. If you have a technical question that does not require an immediate response, you may Fax it to 651-736-7282.

### Replacement Parts and Additional Manuals

Order parts by part number, part description and quantity required. Also, when ordering parts and/or additional manuals, include machine name, number and type. A parts order form is provided at the back of this manual.

#### **3M/Tape Dispenser Parts**

**241 Venture Drive**

**Amery, WI 54001-1325**

**1-800/344 9883**

**FAX# 715/268 8153**

**Minimum billing on parts orders will be \$25.00. Replacement part prices available on request.**

**\$10.00 restocking charge per invoice on returned parts.**

Note: Outside the U.S., contact the local 3M subsidiary for parts ordering information.



**3M Industrial Adhesives and Tapes**

3M Center, Building 220-5E-06  
St. Paul, MN 55144-1000

3M-Matic™, AccuGlide™ and Scotch™ are Trademarks of  
3M, St. Paul, MN 55144-1000

Printed in U.S.A.

© 3M 2005 44-0009-1851-4 (F)

## To Our Customers:

**This is the 3M-Matic™/AccuGlide™/Scotch® equipment you ordered. It has been set up and tested in the factory with Scotch® tapes. If any problems occur when operating this equipment and you desire a service call or phone consultation, call, write or fax the appropriate number listed below.**

**Included with each machine is an Instructions and Parts List manual.**

**SERVICE, REPLACEMENT PARTS AND ADDITIONAL MANUALS  
AVAILABLE DIRECT FROM:**

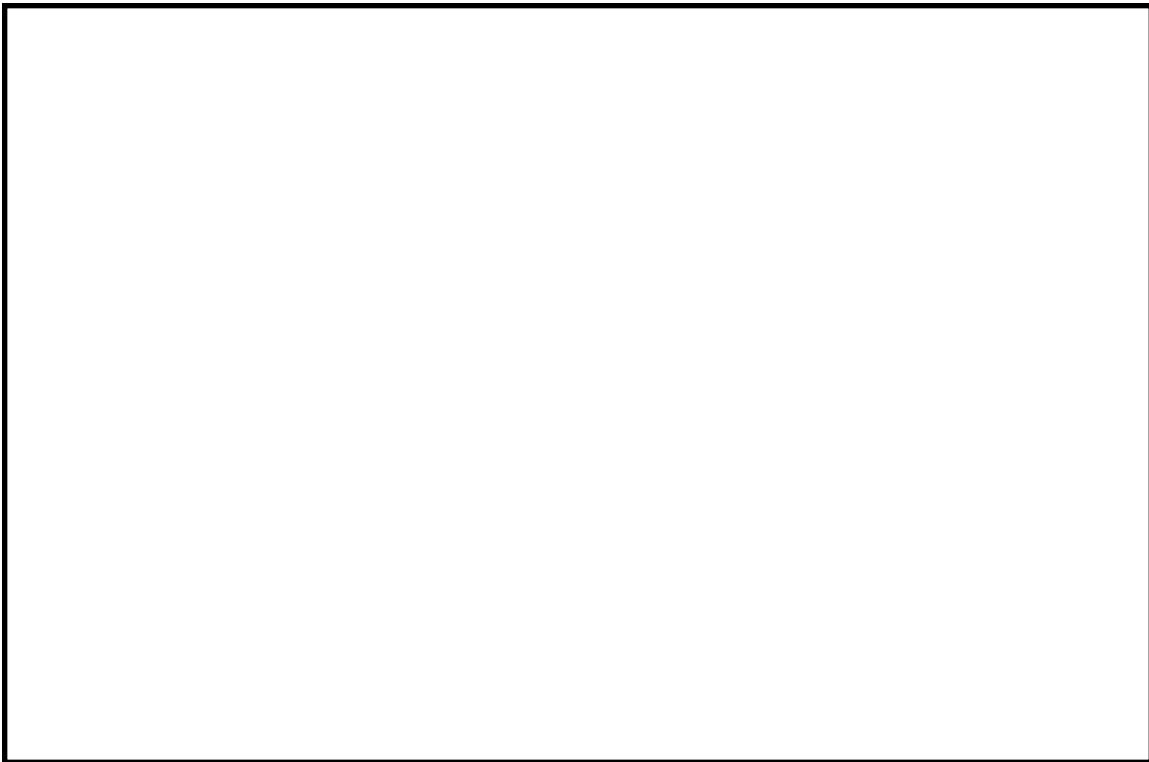

Order parts by part number, part description and quantity required. Also, when ordering parts and/or additional manuals, include machine name, number and type.

**3M**

**3M Industrial Adhesives and Tapes**  
3M Center, Building 220-5E-06  
St. Paul, MN 55144-1000

3M-Matic™, AccuGlide™ and Scotch™ are Trademarks of  
3M, St. Paul, MN 55144-1000

Printed in U.S.A.

© 3M 2005 44-0009-1852-2(E)

# Instruction Manual

## 110a, Adjustable Case Sealer, Type 10500

This instruction manual is divided into two sections as follows:

- Section I** Includes all information related to installation, operation and parts for the case sealer.
- Section II** Includes specific information regarding the AccuGlide™ 2+ STD 2 Inch Taping Heads.

---

### Table of Contents

Page

---

#### Section I – 110a Adjustable Case Sealer

Intended Use .....	1
Equipment Warranty and Limited Remedy .....	2
110a Contents .....	2
Important Safeguards .....	3 - 5
Specifications .....	6 - 8
Installation and Set-Up .....	9 - 14
Receiving and Handling .....	9
Machine Set-Up .....	9 - 14
Packaging and Separate Parts .....	9 - 11
Positioning the Columns .....	11
Machine Bed Height .....	13
Tape Leg Length .....	13
Electrical Connection and Controls .....	14
Initial Start-Up of Case Sealer .....	14
Operation .....	15 - 19
Electrical On/Off Switch .....	16
Emergency Stop Switch .....	16
Tape Loading/Threading .....	16
Box Size Set-Up .....	17 - 18
Adjust Upper Taping Head .....	17
Adjust Side Guides .....	17
Run Boxes To Check Adjustment .....	18
Top Flap Compression Rollers .....	18
Adjust Compression Rollers .....	18
Box Sealing .....	19

(Table of Contents continued on next page)

## Table of Contents (Continued)

Page

---

Maintenance .....	20 - 22
Cleaning .....	20
Lubrication .....	20
Box Drive Belt Replacement .....	21
Circuit Breaker .....	22
Blade Replacement, Taping Head .....	22
Adjustments .....	23 - 25
Box Drive Belt Tension .....	23 - 24
Taping Head Adjustments .....	25
Special Set-Up Procedure .....	26
Taping Head .....	26
Troubleshooting .....	27
Electrical Diagram .....	28
Parts and Service Information .....	29
Options/Accessories .....	30
Replacement Parts - Illustrations and Parts Lists .....	31 - 52

## Section II – AccuGlide™ 2+ STD 2 Inch Taping Heads

(See Section II for Table of Contents)

---

## Intended Use

---

The **3M-Matic™ 110a Adjustable Case Sealer** with **AccuGlide™ 2+** Taping Heads is designed to apply a “C” clip of **Scotch®** pressure-sensitive film box sealing tape to the top and bottom center seam of regular slotted containers. The 110a is manually adjustable to a wide range of box sizes (see "Specifications Section – Box Weight and Size Capacities").

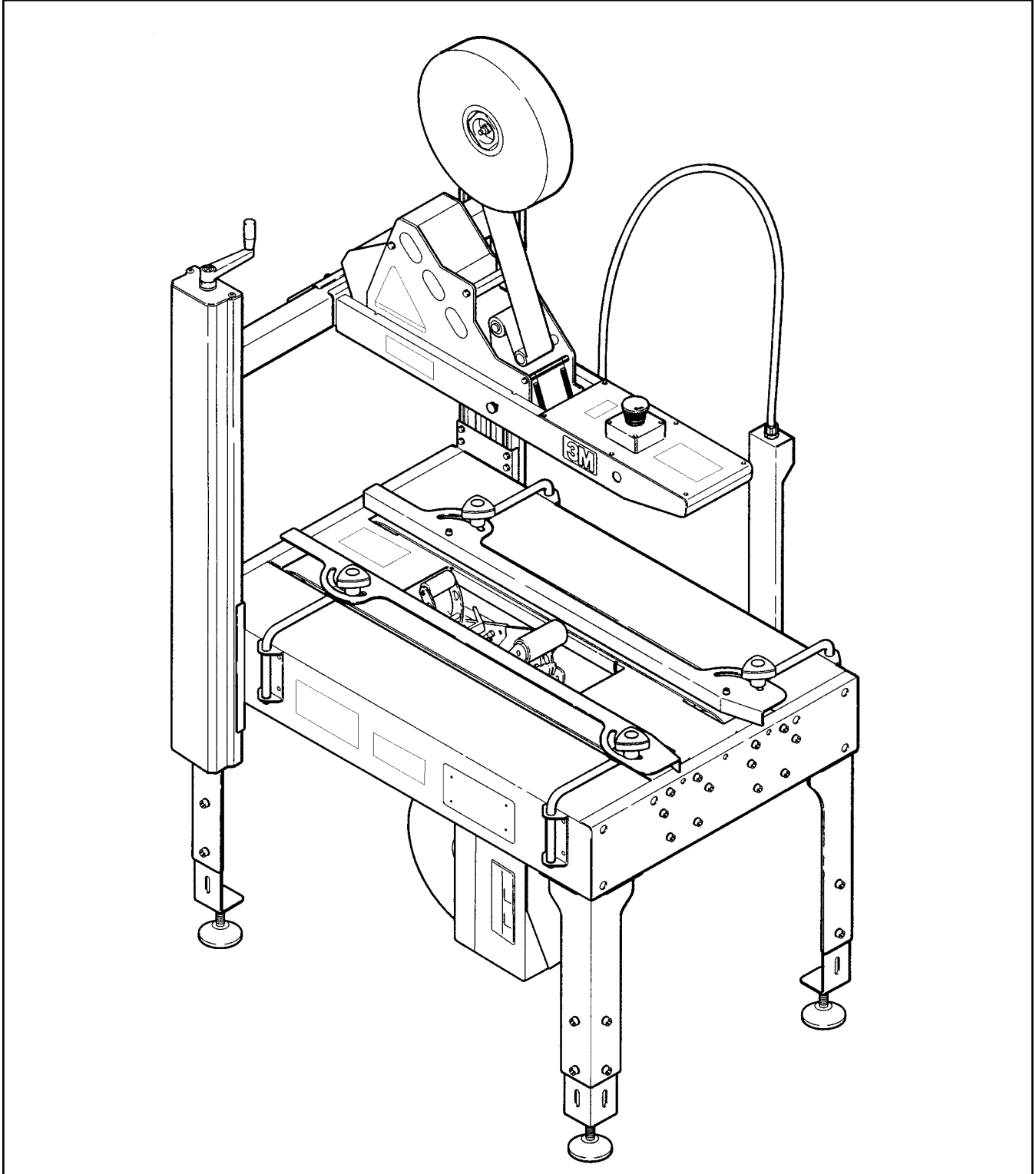

**3M-Matic™ 110a Adjustable Case Sealer, Type 10500**

**Equipment Warranty and Limited Remedy: THE FOLLOWING WARRANTY IS MADE IN LIEU OF ALL OTHER WARRANTIES, EXPRESS OR IMPLIED, INCLUDING, BUT NOT LIMITED TO, THE IMPLIED WARRANTY OF MERCHANTABILITY, THE IMPLIED WARRANTY OF FITNESS FOR A PARTICULAR PURPOSE AND ANY IMPLIED WARRANTY ARISING OUT OF A COURSE OF DEALING, A CUSTOM OR USAGE OF TRADE:**

3M sells its **3M-Matic™ 110a Adjustable Case Sealer, Type 10500** with the following warranties:

1. The drive belts and the taping head knives, springs and rollers will be free from all defects for ninety (90) days after delivery.
2. All other taping head parts will be free from all defects for three (3) years after delivery.
3. All other parts will be free from all defects for two (2) years after delivery.

If any part is proved to be defective within its warranty period, then the exclusive remedy and 3M's and seller's sole obligation shall be, at 3M's option, to repair or replace the part, provided the defective part is returned immediately to 3M's factory or an authorized service station designated by 3M. A part will be presumed to have become defective after its warranty period unless the part is received or 3M is notified of the problem no later than five (5) calendar days after the warranty period. If 3M is unable to repair or replace the part within a reasonable time, then 3M at its option, will replace the equipment or refund the purchase price. 3M shall have no obligation to provide or pay for the labor required to install the repaired or replacement part. 3M shall have no obligation to repair or replace (1) those parts failing due to operator misuse, carelessness, or due to any accidental cause other than equipment failure, or (2) parts failing due to non-lubrication, inadequate cleaning, improper operating environment, improper utilities or operator error.

**Limitation of Liability:** 3M and seller shall not be liable for direct, indirect, special, incidental or consequential damages based upon breach of warranty, breach of contract, negligence, strict liability or any other legal theory.

The foregoing Equipment Warranty and Limited Remedy and Limitation of Liability may be changed only by a written agreement signed by authorized officers of 3M and seller.

---

## **Contents – 110a Adjustable Case Sealer**

---

- (1) 110a Adjustable Case Sealer, Type 10500
- (1) Upper Assembly Height Adjustment Crank/Hardware
- (1) Tool/Spare Parts Kit
- (1) Instruction and Parts Manual

## Important Safeguards

 This safety alert symbol identifies important messages in this manual. **READ AND UNDERSTAND THEM BEFORE INSTALLING OR OPERATING THIS EQUIPMENT.**

### Explanation of Signal Word Consequences

 **WARNING:** Indicates a potentially hazardous situation, which, if not avoided, could result in death or serious injury and/or property damage.

 **CAUTION:** Indicates a potentially hazardous situation, which, if not avoided, may result in minor or moderate injury and/or property damage.

## WARNING

- **To reduce the risk associated with mechanical and electrical hazards:**
  - Read, understand and follow all safety and operating instructions before operating or servicing the case sealer
  - Allow only properly trained and qualified personnel to operate and/or service this equipment
- **To reduce the risk associated with pinch, entanglement and hazardous voltage:**
  - Turn electrical supply off and disconnect before performing any adjustments, maintenance or servicing the machine or taping heads
- **To reduce the risk associated with pinch and entanglement hazards:**
  - Do not leave the machine running while unattended
  - Turn the machine off while not in use
  - Never attempt to work on any part of the machine, load tape, or remove jammed boxes from the machine while the machine is running
- **To reduce the risk associated with hazardous voltage:**
  - Position electrical cord away from foot and/or vehicle traffic

## WARNING (continued)

- **To reduce the risk associated with sharp blade hazards:**
  - Keep hands and fingers away from tape cutoff blades under orange blade guards. The blades are extremely sharp
- **To reduce the risk associated with fire and explosion hazards:**
  - Do not operate this equipment in potentially flammable/explosive environments
- **To reduce the risk associated with muscle strain:**
  - Use the appropriate rigging and material handling equipment when lifting or repositioning this equipment
  - Use proper body mechanics when removing or installing taping heads that are moderately heavy or may be considered awkward to lift

## CAUTION

- **To reduce the risk associated with pinch hazards:**
  - Keep hands clear of the upper head support assembly as boxes are transported through the machine
  - Keep hands, hair, loose clothing and jewelry away from box compression rollers
  - Always feed boxes into the machine by pushing only from the end of the box
  - Keep hands, hair, loose clothing, and jewelry away from moving belts and taping heads



# Important Safeguards (Continued)

**Important** – In the event the following safety labels are damaged or destroyed, **they must be replaced to ensure operator safety**. Replacement part numbers for individual labels are shown in Figures 1-1, or a label kit, part number 78-8133-9619-5, is available that includes all labels used on the machine.

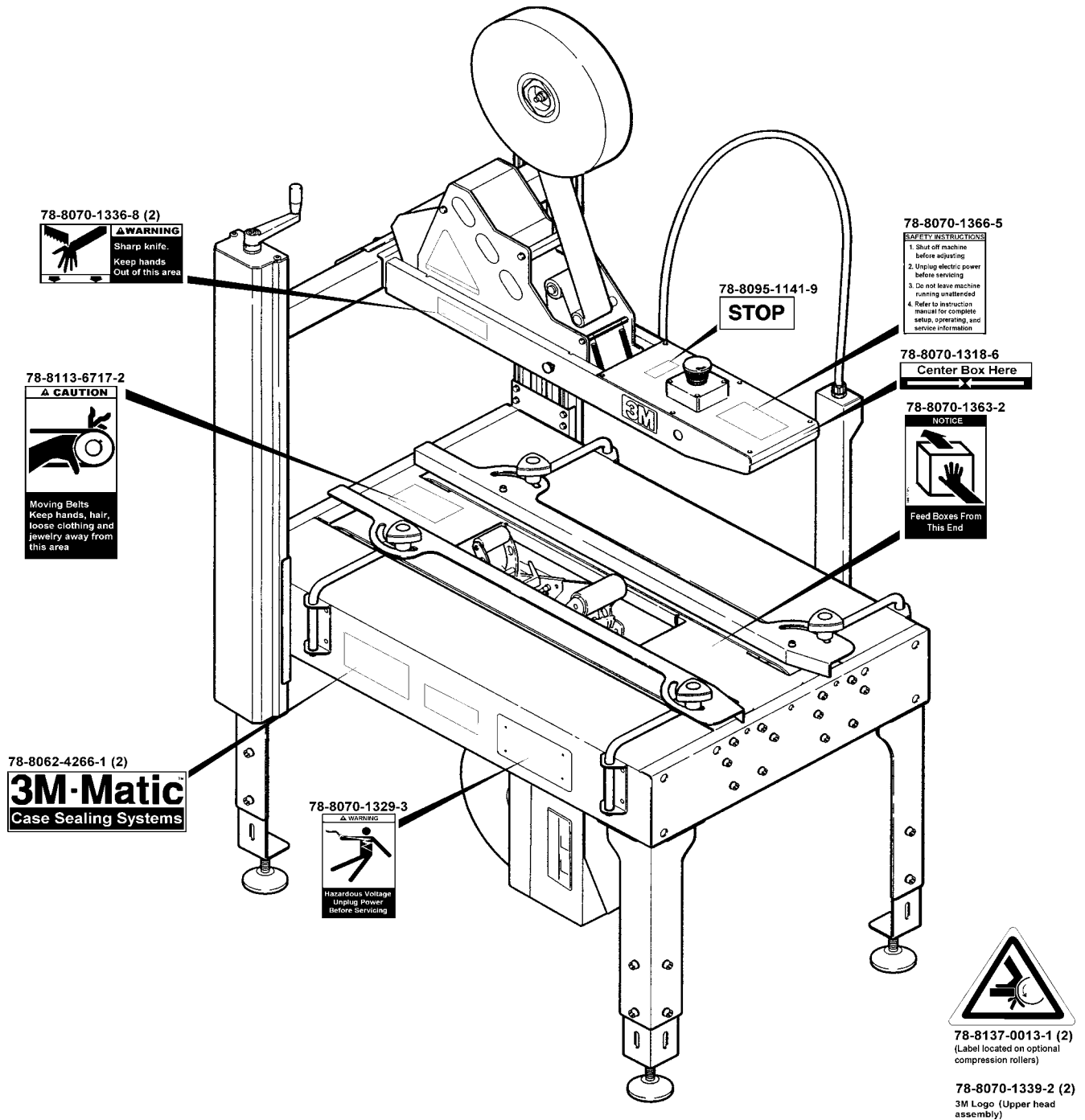

Figure 1-1 – Replacement Labels/3M Part Numbers

## Important Safeguards (Continued)



### WARNING

- **To reduce the risk associated with mechanical and electrical hazards:**
  - Allow only properly trained and qualified personnel to operate and/or service this equipment

### Operator Skill Level Descriptions

#### **Skill 1 - Machine Operator**

This operator is trained to use the machine with the machine controls, to feed cases into the machine, make adjustments for different case sizes, to change the tape and to start, stop and restart production.

**Important** – the factory manager must ensure that the operator has been properly trained on all the machine functions before starting work.

#### **Skill 2 - Mechanical Maintenance Technician**

This operator is trained to use the machine as the MACHINE OPERATOR and in addition is able to work with the safety protection disconnected, to check and adjust mechanical parts, to carry out maintenance operations and repair the machine. He is not allowed to work on live electrical components.

#### **Skill 2a - Electrical Maintenance Technician**

This operator is trained to use the machine as the MACHINE OPERATOR and in addition is able to work with the safety protection disconnected, to make adjustments, to carry out maintenance operations and repair the electrical components of the machine. He is allowed to work on live electrical panels, connector blocks, control equipment, etc.

#### **Skill 3 - Specialist From the Manufacturer**

Skilled operator sent by the manufacturer or its agent to perform complex repairs or modifications, when agreed with the customer.

### Operator's Skill Levels Required to Perform the Main Operations on Machine

Operation	State of the Machine	Operator's Skill	Number of Operators
Installation and set up of the machine.	Running with safety protections disabled.	2 and 2a	2
Adjustment of the box size.	Stopped by pressing the EMERGENCY STOP button.	1	1
Tape replacement.	Stopped by pressing the EMERGENCY STOP button.	1	1
Replacement of blades.	Electric power disconnected.	2	1
Replacement of drive belts.	Electric power disconnected.	2	1
Ordinary maintenance.	Electric power disconnected.	2	1
Extraordinary maintenance (mechanical).	Running with safety protections disabled.	3	1
Extraordinary maintenance (electrical).	Running with safety protections disabled.	2a	1

---

## Specifications

---

### 1. Power Requirements:

Electrical - 115 VAC, 60 Hz, 2.9 A (340 watts)

The machine is equipped with a 2.4 m [8 foot] standard neoprene covered power cord and a grounded plug. Contact your 3M Representative for power requirements not listed above.

### 2. Operating Rate:

Box drive belt speed is approximately 0.4 m/s [78 feet per minute].

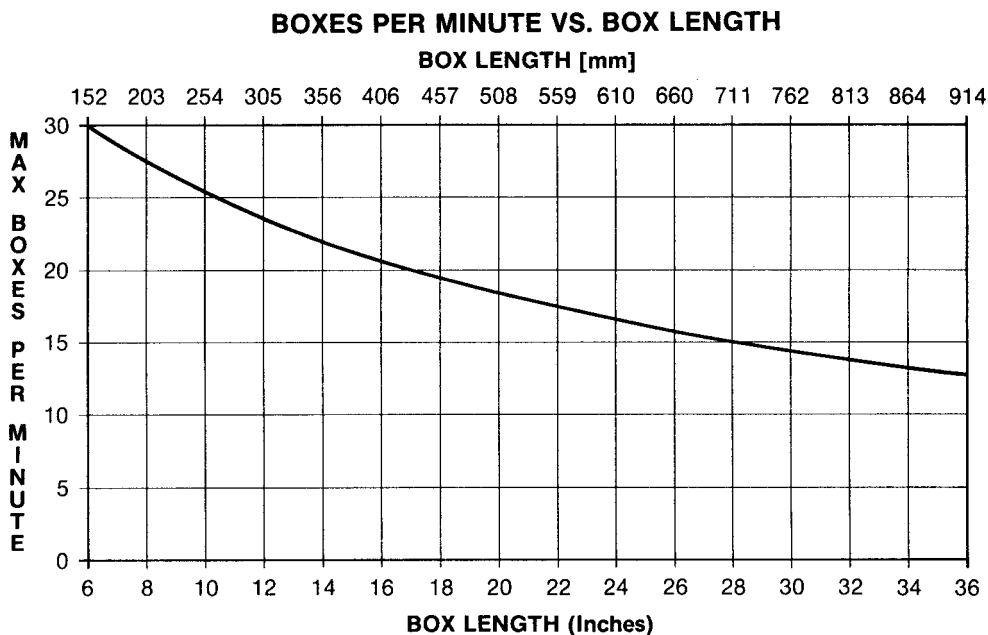

Actual production rate is dependent on operator's dexterity.

Boxes must be 18 inches [455mm] apart minimum.

### 3. Operating Conditions:

Use in dry, relatively clean environments at 5° to 40° C [40° to 105° F] with clean, dry boxes.

**Note:** Machine should not be washed down or subjected to conditions causing moisture condensation on components.

 <b>WARNING</b>
<ul style="list-style-type: none"><li>• <b>To reduce the risk associated with fire and explosion hazards:</b><ul style="list-style-type: none"><li>— Do not operate this equipment in potentially flammable/explosive environments</li></ul></li></ul>

### 4. Tape:

Scotch® pressure-sensitive film box sealing tapes.

### 5. Tape Width:

36 mm [1 1/2 inch] minimum to 48 mm [2 inch] maximum

(Specifications continued on next page.)

## Specifications (Continued)

### 6. Tape Roll Diameter:

Up to 405 mm [16 inch] maximum on a 76.2 mm [3 inch] diameter core.  
(Accommodates all system roll lengths of **Scotch®** film tapes.)

### 7. Tape Application Leg Length – Standard:

70 mm ± 6 mm [2.75 inch ±.25 inch ]

### Tape Application Leg Length – Optional:

50 mm ± 6 mm [2 inch ±.25 inch]

(See "Special Set-Up Procedure – Changing the Tape Leg Length".)

### 8. Box Board:

Style – regular slotted containers – RSC  
125 to 275 P.S.I. bursting test, single wall or double wall B or C flute.

### 9. Box Weight and Size Capacities:

A. Box Weight, filled – up to 38.6 kg [85 lbs.] maximum. Contents must support flaps.

B. Box Size:	Minimum	Maximum
Length –	150 mm [6.0 inch]	Unlimited
Width –	150 mm [6.0 inch]*	572 mm [22.5 inch]
Height –	120 mm [4.75 inch]**	572 mm [22.5 inch]

\* Cartons narrower than 250 mm [10 inch] in width may require more frequent belt replacement because of limited contact area.

\*\* 90 mm [3.5 inch] height with heads adjusted to apply 50 mm [2 inch] tape leg lengths. (See "Special Set-Up Procedure – Changing the Tape Leg Length".)

**Special modifications may be available for carton sizes not listed above.  
Contact your 3M Representative for information.**

**Note:** The case sealer can accommodate most boxes within the size range listed above. However, if the box length (in direction of seal) to box height ratio is .5 or less, then several boxes should be test run to assure proper machine performance.

**DETERMINE THE BOX LIMITATIONS BY COMPLETING THIS FORMULA:**

$$\frac{\text{BOX LENGTH IN DIRECTION OF SEAL}}{\text{BOX HEIGHT}} = \text{MUST BE GREATER THAN .5}$$

Any box ratio approaching this limitation should be test run to assure performance.

(Specifications continued on next page.)

## Specifications (Continued)

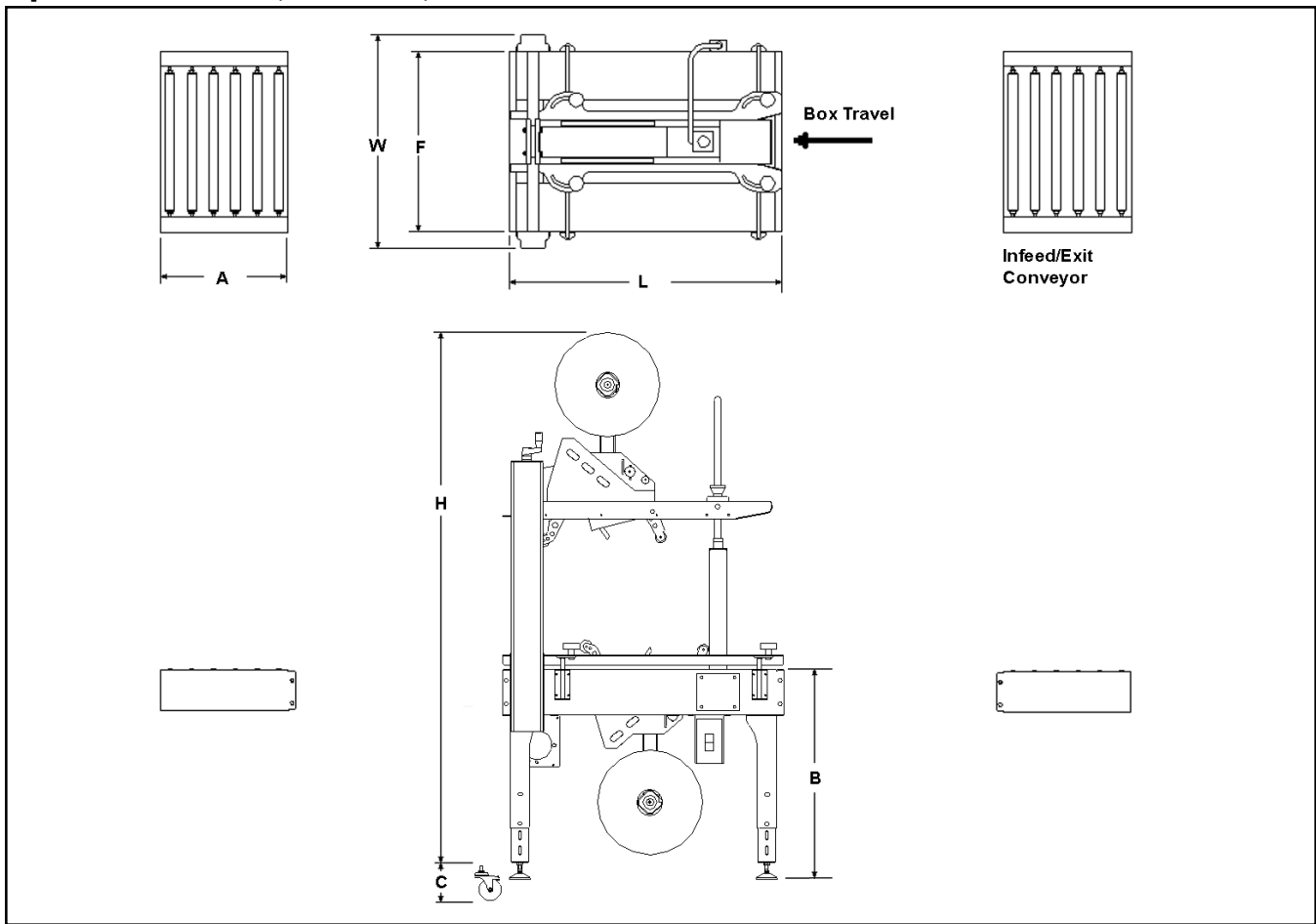

### 10. Machine Dimensions:

	W	L	H	A*	B	C**	F
<b>Minimum</b>							
mm	737	940	1367	451	572	122	622
[Inches]	[29]	[37]	[53.8]	[17.75]	[22.5]**	[4.8]	[24.5]
<b>Maximum</b>							
mm	--	--	2083	--	851	--	--
[Inches]	--	--	[82]**	--	[33.5]**	--	--

\* Infeed/Exit conveyors are optional

\*\* Casters are optional

Weight – 132 kg [291 lbs] crated (approximate)  
 96 kg [212 lbs] uncrated (approximate)

### 11. Set-Up Recommendations:

- Machine must be level.
- Customer supplied infeed and exit conveyors (if used) should provide straight and level box entry and exit.
- Exit conveyors (powered or gravity) must convey sealed boxes away from machine.

# Installation and Set-Up

## Receiving And Handling

After the machine has been uncrated, examine the case sealer for damage that might have occurred during transit. **If damage is evident, file a damage claim immediately** with the transportation company and also notify your 3M Representative.

## Machine Set-Up

### **WARNING**

- **To reduce the risk associated with mechanical and electrical hazards:**
  - Read, understand and follow all safety and operating instructions before operating or servicing the case sealer

The following instructions are presented in **the order recommended** for setting up and installing the case sealer, as well as **for learning the operating functions and adjustments**. Following them step by step will result in your thorough understanding of the machine and an installation in your production line that best utilizes the many features built into the case sealer. Refer to Figure 3-1 to identify the various components of the case sealer.

**Note** – A tool kit consisting of metric open end and hex socket wrenches is provided with the machine. These tools should be adequate to set-up the machine, however, other tools supplied by the customer will be required for machine maintenance.

### PACKAGING AND SEPARATE PARTS

1. Remove straps and staples and lift fiberboard cover off pallet.

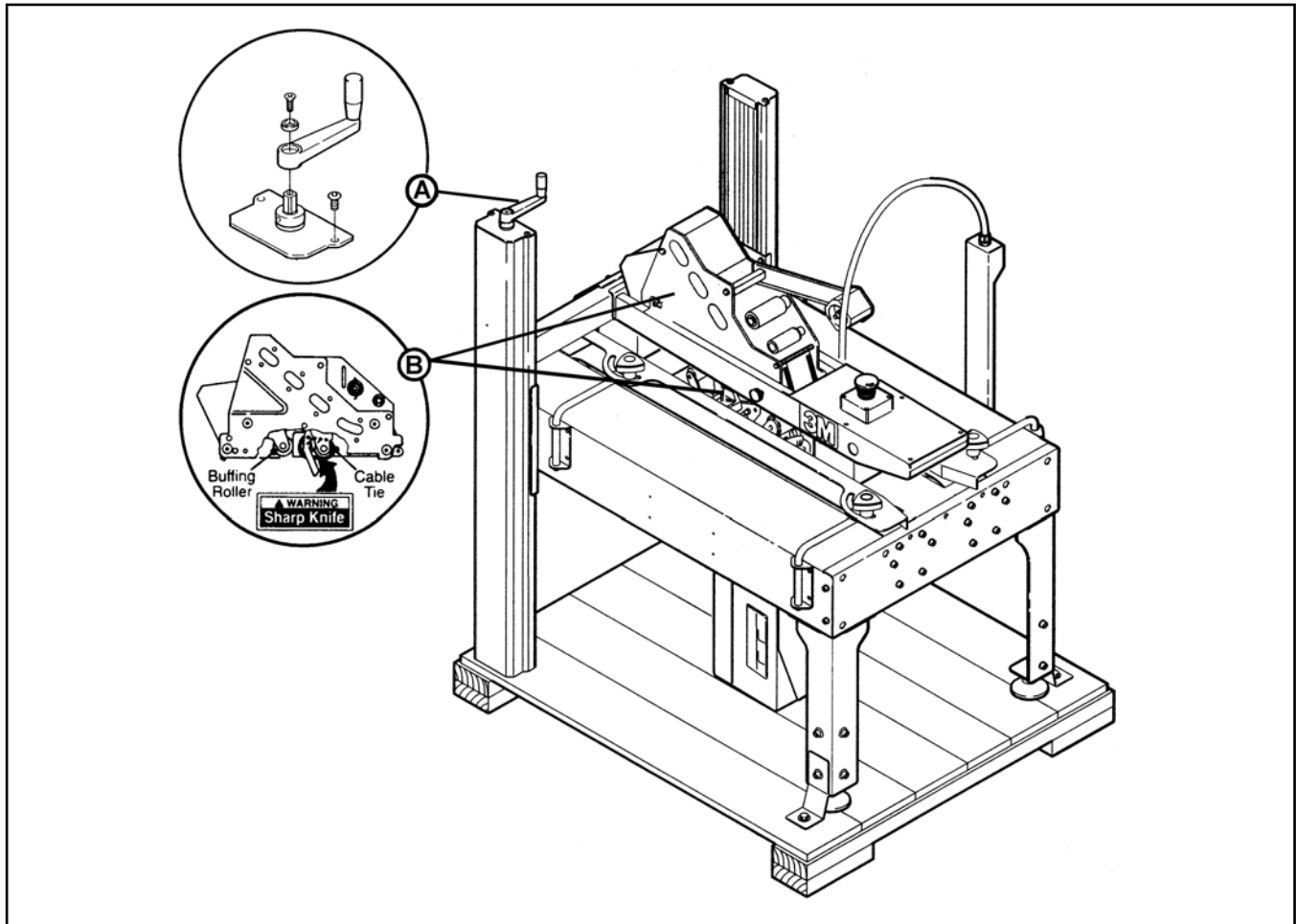

Figure 2-1 – 110a Frame Set-Up

## Installation and Set-Up (Continued)

### **WARNING**

- **To reduce the risk associated with muscle strain:**
  - Use the appropriate rigging and material handling equipment when lifting or repositioning this equipment
  - Use proper body mechanics when removing or installing taping heads that are moderately heavy or may be considered awkward to lift

2. Remove the machine from the pallet and move it into position.

**Important** – Whenever the machine is lifted with a fork truck, ensure that the forks span completely across the machine frame and do not contact any wiring or mechanism under the machine frame. In some cases the lower taping head may need to be removed to avoid damage.

### **WARNING**

- **To reduce the risk associated with sharp blade hazards:**
  - Keep hands and fingers away from tape cutoff blades under orange blade guards. The blades are extremely sharp

**Note** – Hold taping head **BUFFING ROLLER** and cut and remove cable tie that holds applying/buffing arms retracted. See Figure 2-2B. Allow buffing/applying arms to extend slowly.

3. Check for free action of both upper and lower taping heads.  
Push buffing roller into head to check for free, smooth action of taping heads.
4. Ensure that the tape drum bracket assembly, located on the upper and lower taping heads, is mounted straight, as shown in Figure 2-2. The tape drum bracket assembly can be pivoted to provide tape roll clearance in certain cases.

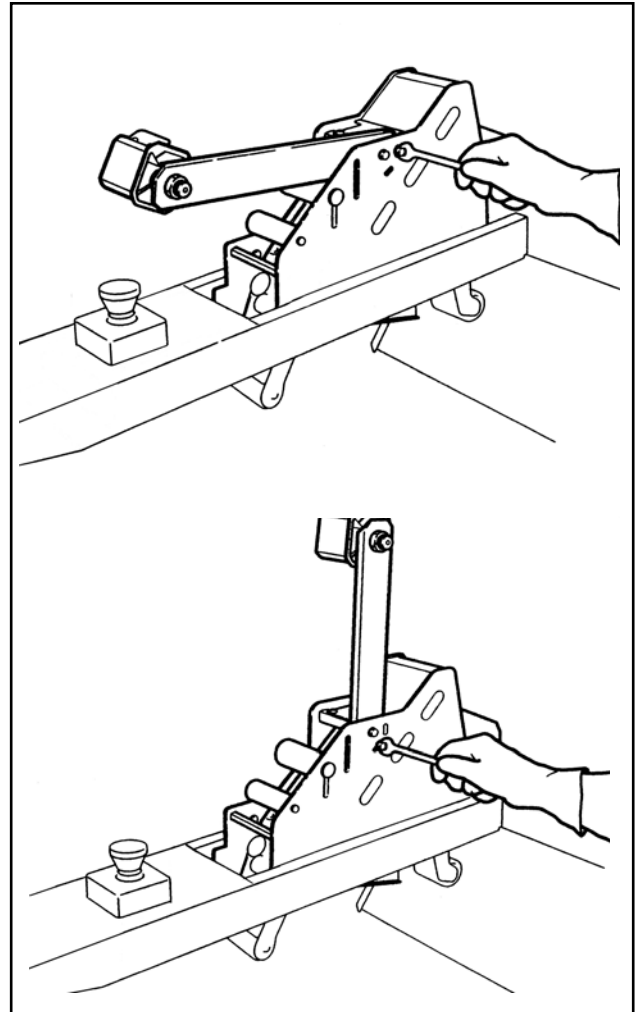

**Figure 2-2 – Lower Tape Drum Bracket Position**

## Installation and Set-Up (Continued)

5. Remove the fasteners that secure the case sealer legs to pallet, as shown in Fig. 2-3.

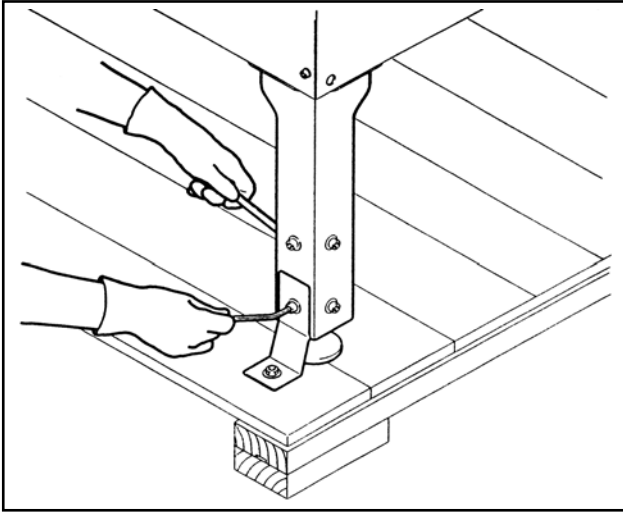

**Figure 2-3 – Remove Fasteners**

6. Cut the plastic straps that fix the top head to the frame and remove the polystyrene blocks, as shown in Fig. 2-4.

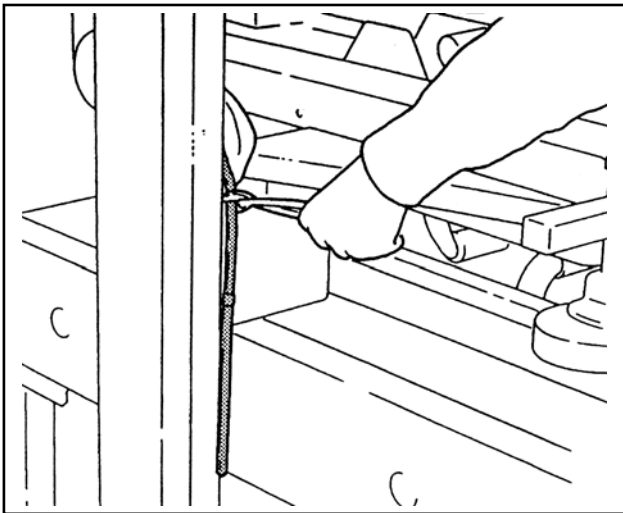

**Figure 2-4 – Cut the Plastic Straps**

7. Cut the plastic ties holding the upper and lower taping heads in position, as shown in Fig. 2-5.

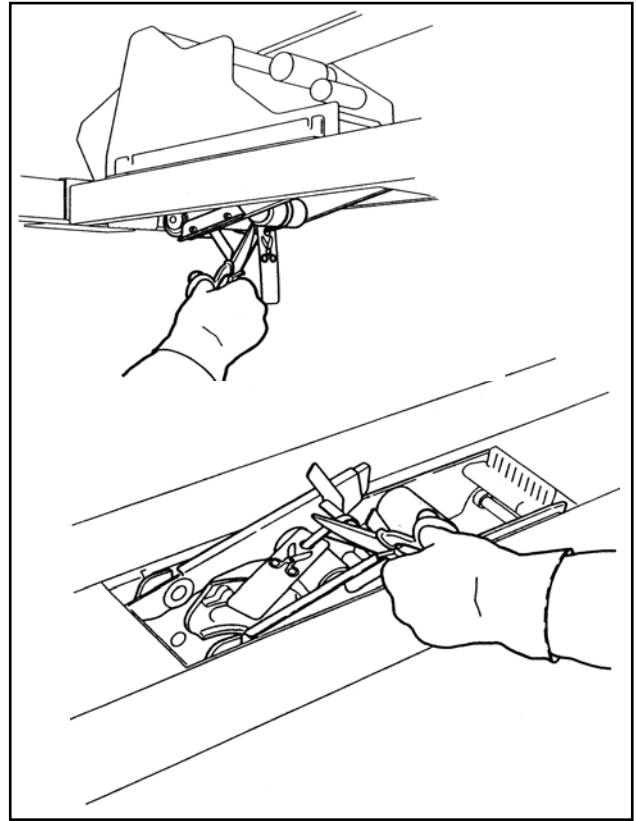

**Figure 2-5 – Cut the Plastic Ties**

### POSITIONING THE COLUMNS

1. Remove handle screw and reposition as shown in figure 2-1. Use the height adjustment handle to raise the upper head.
2. Insert rigid supports, approximately 10 inch height, on the bottom driving belts and lower the upper head until it is resting on the supports.

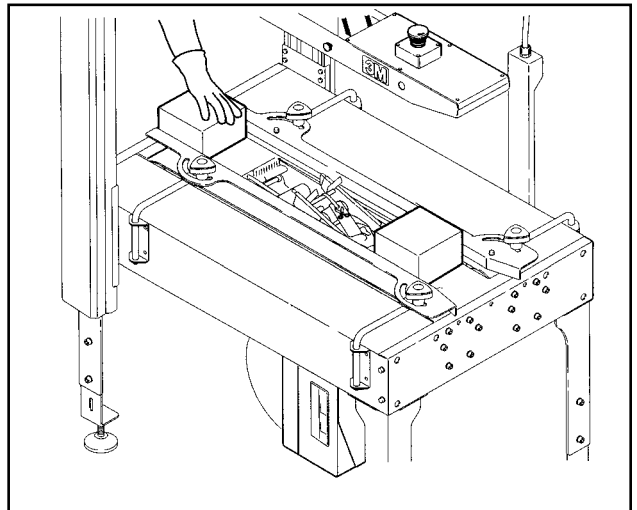

**Figure 2-6 – Support the Upper Head**



## Installation and Set-Up (Continued)

3. Remove the two screws (**A**) that fasten the column (with the handle) to the bench of the machine, as shown in Fig. 2-7.

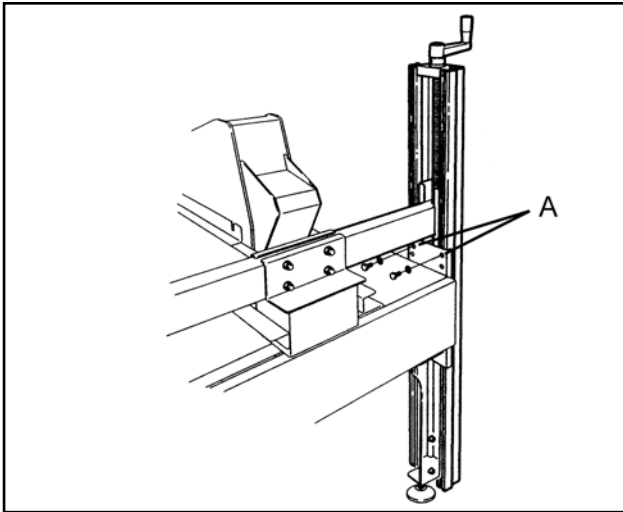

Figure 2-7 – Remove the Two Screws

4. Turn the handle counterclockwise to raise the column until it is aligned with the holes, as shown in Fig. 2-8.

Take the two screws from the spare parts kit and fasten the column (four screws are required for each column).

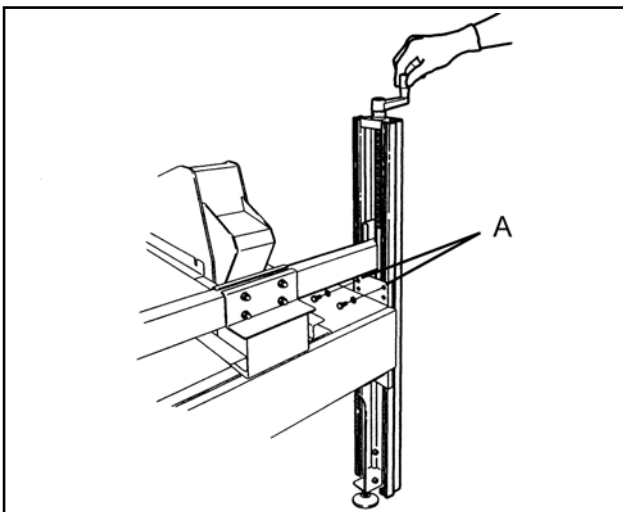

Figure 2-8 – Fasten the Column

5. Hold the opposite side column (without the handle) and remove the two screws (**B**), as shown in Fig. 2-9.

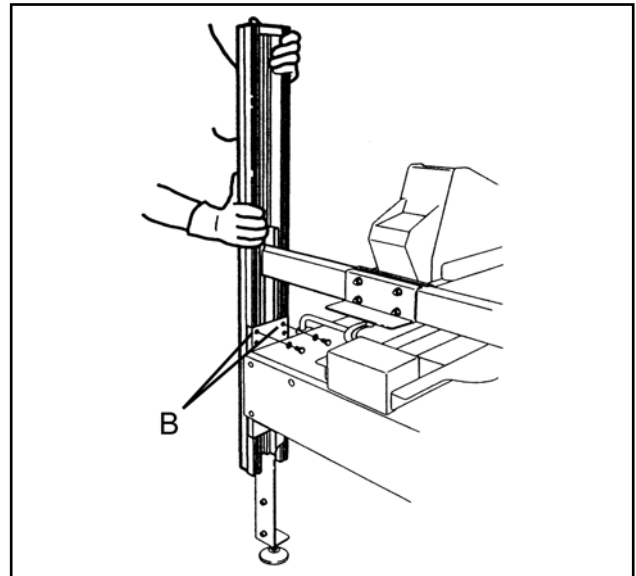

Figure 2-9 – Remove the Two Screws

6. Raise the column until the holes (**B**) align with the corresponding frame bracket holes. Take the two screws from the spare parts kit (four screws are required for each column), and fasten the column, as shown in Fig. 2-10.

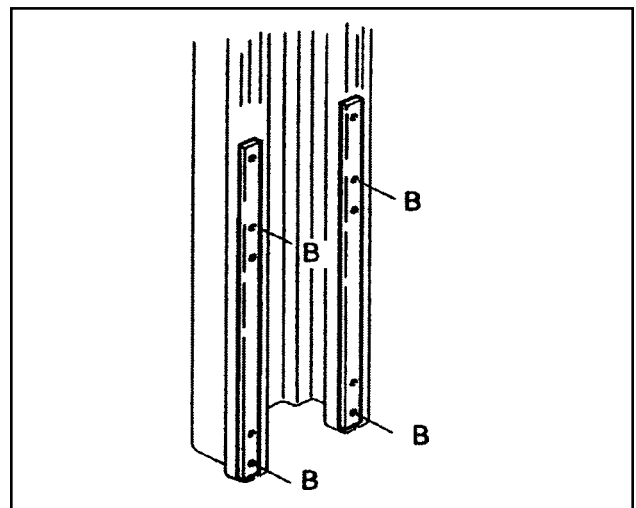

Figure 2-10 – Fasten the Column

7. Raise the upper head by turning the handle clockwise, and remove the supports.

## Installation and Set-Up (Continued)

### MACHINE BED HEIGHT

Adjust machine bed height. The case sealer is equipped with four adjustable legs that are located at the corners of the machine frame. The legs can be adjusted to obtain different machine bed heights. See the "Specifications" section.

**Note** – Minimum machine bed height can be reduced to 520 mm [20.5 inch] by moving outer columns up one set of mounting holes. However, this change also reduces minimum box height of 120 mm [4.8 inch] to 165 mm [6.5 inch]. (See "Special Set-Up Procedure – Box/Machine Bed Height Range".)

Refer to Figure 2-11A&B and set the machine bed height as follows:

1. Use appropriate material handling equipment and blocking techniques to raise the machine frame to allow adequate leg adjustment.
2. Loosen the socket head screws that hold the inner leg assembly to the machine (Fig. 2-11A). Adjust the leg length for the desired machine bed height. Retighten the screws. Adjust all four legs equally.
3. Use a 19mm open-end wrench to unlock the nut and adjust the height of each foot (Fig. 2-11B). Lock the nut of each foot before adjusting another.

**Note** – it is not necessary to fix or anchor the machine to the floor.

### WARNING

- To reduce the risk associated with muscle strain:
  - Use the appropriate rigging and material handling equipment when lifting or repositioning this equipment
  - Use proper body mechanics when removing or installing taping heads that are moderately heavy or may be considered awkward to lift

### TAPE LEG LENGTH

Taping heads are pre-set to apply 70 mm [2.75 inch] long tape legs. To change tape leg length to 50 mm [2.0 inch], see "Special Set-Up Procedure – Changing the Tape Leg Length".

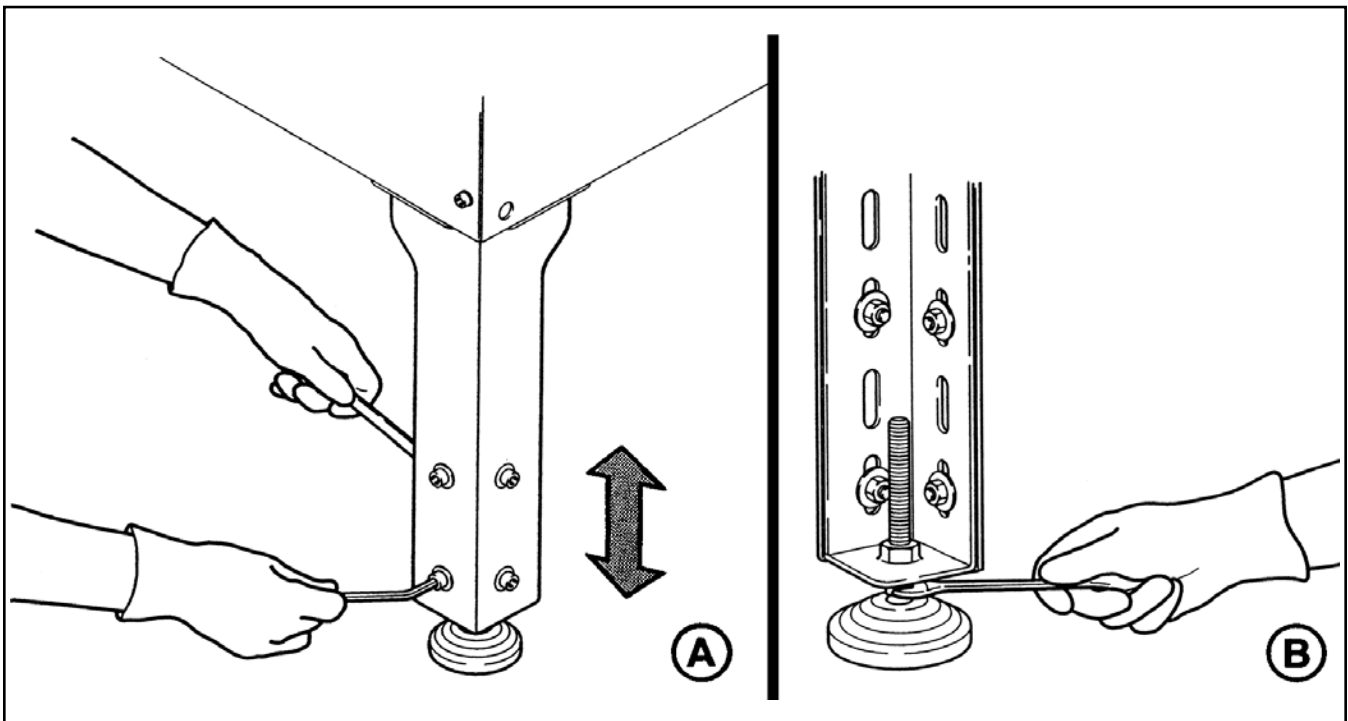

Figure 2-11 – Machine Bed Height Adjustment and Lower Tape Drum Bracket Position

## Installation and Set-Up (Continued)

### ELECTRICAL CONNECTION AND CONTROLS

The electrical control box (with circuit breaker) and "On/Off" switch are located on the lower left side of the machine frame. See Figure 3-1. If desired, for operator convenience, the "On/Off" switch can be relocated to the right side of the machine frame. A standard three-conductor power cord with plug is provided at the back of the electrical control box. The receptacle providing this service shall be properly grounded. Before the power cord is plugged into 115 Volt, 60 Hz outlet make sure that all packaging materials and tools are removed from the machine. **Do not plug electrical cord into outlet until ready to run machine.**

Use of an extension cord is not recommended. However, if one is needed for temporary use, it must have a wire size of 1.5 mm diameter [AWG 16 ], have a maximum length of 30.5 m [100 ft], and must be properly grounded.



### WARNING

- **To reduce the risk associated with hazardous voltage:**
  - Position electrical cord away from foot and/or vehicle traffic

**Note** – *Machines outside the U.S. may be equipped with 220/240 Volt, 50 Hz systems or other electrical requirements compatible with local practice.*

### INITIAL START-UP OF CASE SEALER

After completing the "Installation and Set-Up" procedure, continue through "Operation" for tape loading and start-up to be sure case sealer is properly adjusted to run boxes

## Operation

### **WARNING**

- **To reduce the risk associated with mechanical and electrical hazards:**

- Read, understand and follow all safety and operating instructions before operating or servicing the case sealer

Refer to Figure 3-1 below to acquaint yourself with the various components and controls of the case sealer. Also see Figures 3-1 and 3-2 in Section II for taping head components.

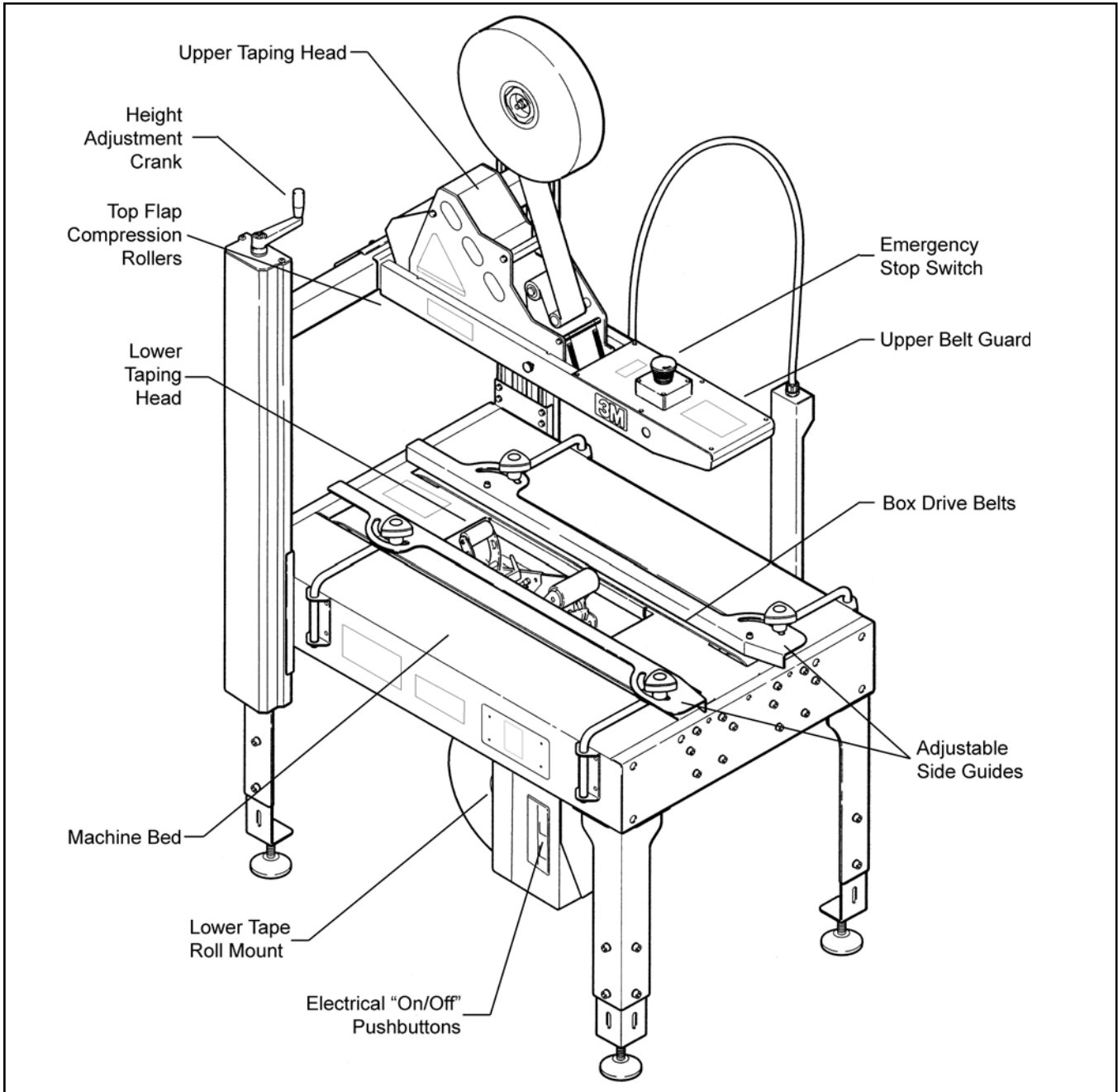

Figure 3-1 – 110a Case Sealer Components (Left Front View)

## Operation (Continued)

**Important** – Before turning drive belts on, be sure no tools or other objects are on the conveyor bed.

### Electrical "On/Off" Switch

The box drive belts are turned on and off ("Off" button is red) with the electrical switch on the side of the machine frame.

**Note** – The case sealer has a circuit breaker located in the electrical enclosure on the machine frame. If circuit becomes overloaded and circuit breaker trips, **unplug the machine electrical cord** and determine cause of overload. After two minutes, open the electrical enclosure and reset the circuit breaker by lifting the reset lever. Close the electrical enclosure, plug machine electrical cord into outlet and restart machine by pressing "I" (On) button.

### Emergency Stop Switch

The machine electrical supply can be turned off by pressing the latching emergency stop switch. To restart machine, rotate emergency stop switch (releases switch latch) and then restart machine by first pressing the red "O" (Off) button to reset the switch then the green "I" (On) button on side of machine frame.

### Tape Loading/Threading

See Section II, Operation Section.

**Note** – Remove the taping head from the machine bed by pulling straight up, insert threading tool in taping head and replace taping head. Install tape roll on drum (adhesive on tape leg up), thread tape under knurled roller on outboard mount, then attach tape to threading needle and pull tape through taping head with threading tool.



## WARNING

- **To reduce the risk associated with muscle strain:**
  - Use proper body mechanics when removing or installing taping heads that are moderately heavy or may be considered awkward to lift

## Operation (Continued)

### Box Size Set-Up

#### 1. ADJUST UPPER TAPING HEAD

The upper taping head is positioned for the box height by means of the height adjustment crank shown in Figure 3-2. Turn crank clockwise to lower head, counterclockwise to raise head.

For machines with the optional box compression rollers: move the top flap compression rollers to a position wider than the box.

Place box on infeed end of machine bed with both top and bottom flaps folded and insert under upper head ski approximately 150 mm [6 inch] as shown in Figure 3-2. Lower the head until all flaps are fully closed. Align box top flap center seam with arrows on front of upper frame.

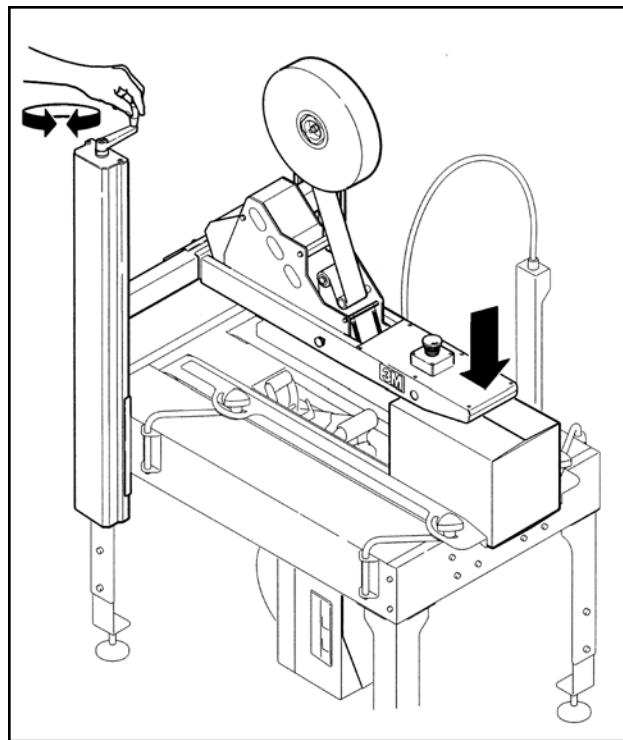

Figure 3-2 – Upper Taping Head

#### 2. ADJUST SIDE GUIDES (Figure 3-3)

Align box top flap center seam with arrows on front of ski.

Move side guides against each side of box to hold box in position, centered on arrows on front of ski.

Tighten hand knobs to secure side guides.

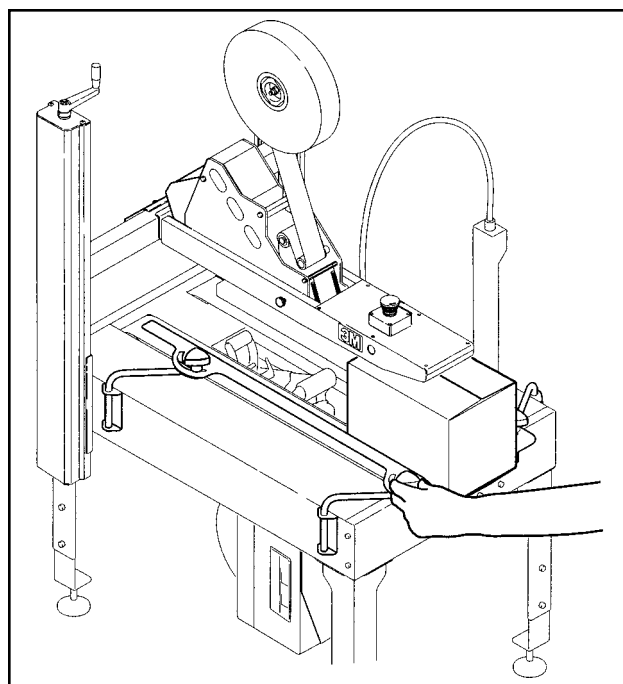

Figure 3-3 – Upper Taping Head

## Operation (Continued)

### 3. RUN BOXES TO CHECK ADJUSTMENT (Figure 3-4)

**Important** – Before turning drive belts on, be sure no tools or other objects are on the conveyor bed.

#### CAUTION

- To reduce the risk associated with pinch hazards:
  - Keep hands clear of the upper head support assembly as boxes are transported through the machine

Turn electrical switch to "**On**" to start drive belts. Move box forward under upper taping head until it is taken away by drive belts. Always push at the end of the box. If box is hard to move under head or is crushed, **raise** head slightly. If box movement is jerky or stops under upper head, **lower** upper head slightly to add more pressure between box and drive belts.

**Note** – Upper head has unique feature for overstuffed boxes. The head will raise up to 13 mm [1/2 inch] to compensate for this type of condition.

**Important** – If drive belts are allowed to slip on box, excessive belt wear will occur.

### 4. TOP FLAP COMPRESSION ROLLERS (Figure 3-5)

**Note** – Steps 4 and 5 are for machines with the optional box compression rollers.

#### CAUTION

- To reduce the risk associated with pinch and entanglement hazards:
  - Keep hands, hair, loose clothing and jewelry away from box compression rollers.

Adjust the top flap compression rollers against top edge of box and tighten knobs to secure rollers in operating position.

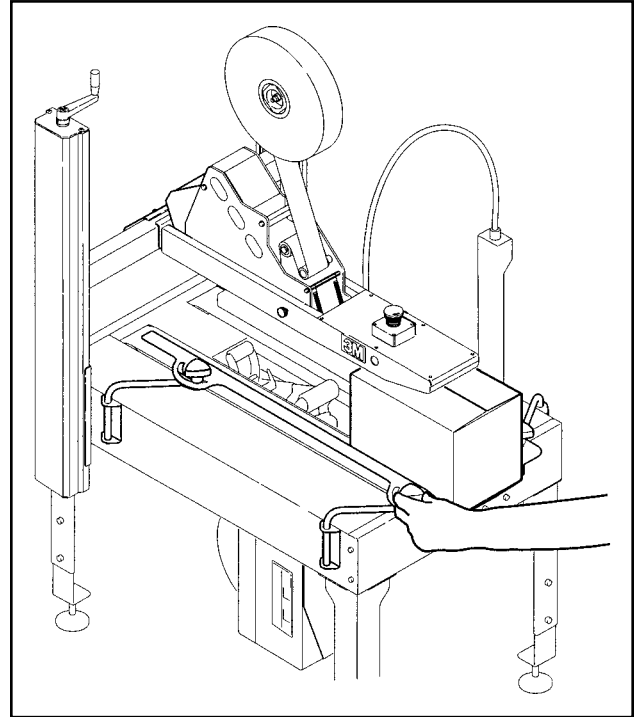

Figure 3-4 – Check Adjustments

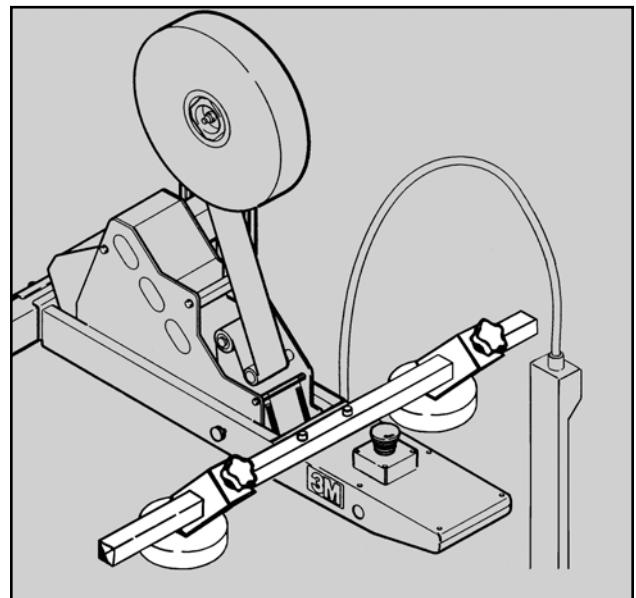

Figure 3-5 – Compression Rollers (optional)

## Operation (Continued)

### Box Sealing



#### CAUTION

- **To reduce the risk associated with pinch hazards:**
  - Keep hands clear of the upper head support assembly as boxes are transported through the machine
  - Always feed boxes into the machine by pushing only from the end of the box
  - Keep hands, hair, loose clothing and jewelry away from box compression rollers
  - Keep hands, hair, loose clothing, and jewelry away from moving belts and taping heads



#### WARNING

- **To reduce the risk associated with pinch, entanglement, and hazardous voltage:**
  - Never attempt to work on any part of the machine, load tape, or remove jammed boxes from the machine while the machine is running

1. Feed boxes to machine at minimum 455 mm [18 inch] intervals.
2. Reload and thread tape as necessary.
3. Be sure machine is cleaned and lubricated according to recommendations in "Maintenance" section of this manual.



#### WARNING

- **To reduce the risk associated with pinch and entanglement hazards:**
  - Do not leave the machine running while unattended

#### Notes—

1. *Machine or taping head adjustments are described in "Adjustments" Section I for machine or Section II for taping heads.*
2. *The box drive motor is designed to run at a moderate temperature of 40°C [104°F]. In some cases, they may feel hot to the touch.*



## Maintenance

The case sealer has been designed for long, trouble free service. The machine will perform best when it receives routine maintenance and cleaning. Machine components that fail or wear excessively should be promptly repaired or replaced to prevent damage to other portions of the machine or to the product.

### **WARNING**

- **To reduce the risk associated with mechanical and electrical hazards:**
  - Read, understand and follow all safety and operating instructions before operating or servicing the case sealer
  - Allow only properly trained and qualified personnel to operate and/or service this equipment
- **To reduce the risk associated with pinch, entanglement and hazardous voltage:**
  - Turn electrical supply off and disconnect before performing any adjustments, maintenance or servicing the machine or taping heads

### Cleaning

**Note** – Never attempt to remove dirt from the machine by blowing it out with compressed air. This can cause the dirt to be blown inside the motor and onto sliding surfaces which may cause premature equipment wear. Never wash down or subject equipment to conditions causing moisture condensation on components. Serious equipment damage could result.

Regular slotted containers produce a great deal of dust and paper chips when processed or handled in equipment. If this dust is allowed to build-up on machine components, it can cause component wear and overheating of drive motor. The dust build-up can best be removed from the machine by a shop vacuum. Depending on the number and type of boxes sealed in the case sealer, this cleaning should be done approximately once per month. If the boxes sealed are dirty, or if the environment in which the machine operates is dusty, cleaning on a more frequent basis may be necessary. Excessive dirt build-up that cannot be removed by vacuuming should be wiped off with a damp cloth.

### Lubrication

Most of the machine bearings, including the drive motor, are permanently lubricated and sealed and do not require additional lubricant.

Figure 4-1 illustrates the machine points that do require lubrication every 250 hours of operation. Lubricate the points indicated by arrows ( ⇔ ) with a small amount of multi-purpose grease.

**Note** – Wipe off excess oil and grease. It will attract dust which can cause premature equipment wear and jamming. Take care that oil and grease are not left on the surface of rollers around which tape is threaded, as it can contaminate the tape's adhesive.

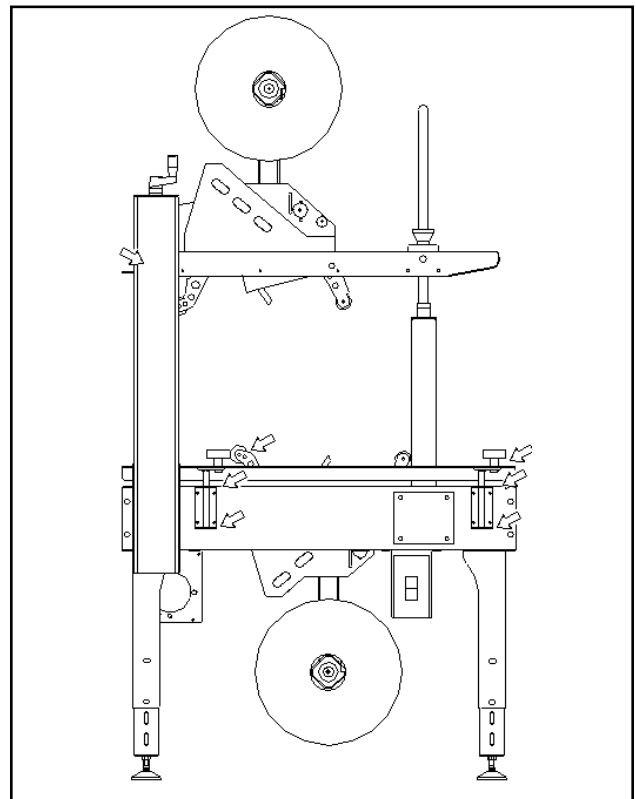

**Figure 4-1 – Lubrication Points – Frame**

## Maintenance (Continued)

### **WARNING**

• **To reduce the risk associated with pinch, entanglement and hazardous voltage:**

- Turn electrical supply off and disconnect before performing any adjustments, maintenance or servicing the machine or taping heads

#### Box Drive Belt Replacement

**Note** – 3M recommends the replacement of drive belts in pairs, especially if belts are unevenly worn.

#### LOWER DRIVE BELTS

Figure 4-2

1. Loosen the belt tension adjustment screws (two per belt) until all belt tension is removed (see Fig. 4-2).
2. Pull belt splicing pin (Fig. 4-3A) out and remove belt.
3. Place new belt over pulleys with laced splice at top (see Fig. 4-4). Insert splicing pin.

**Important** – Pin must not extend beyond edge of belt.

4. Adjust belt tension as explained in "Adjustments - Box Drive Belt Tension."

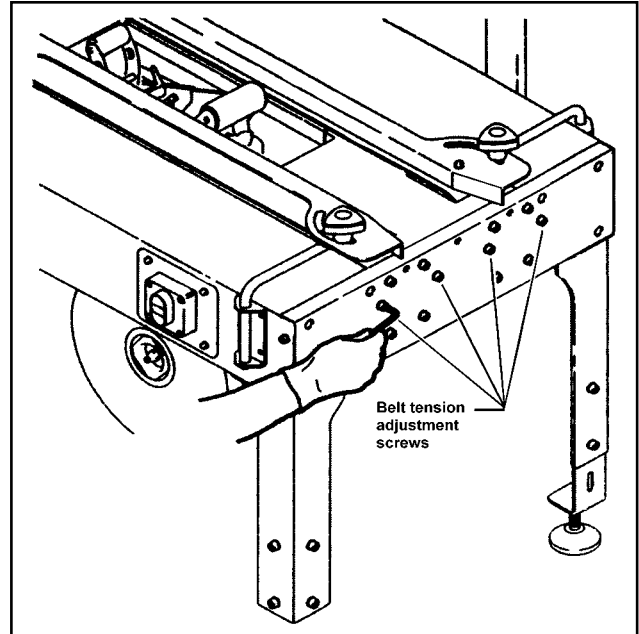

Figure 4-2 - Loosen Belt Tension

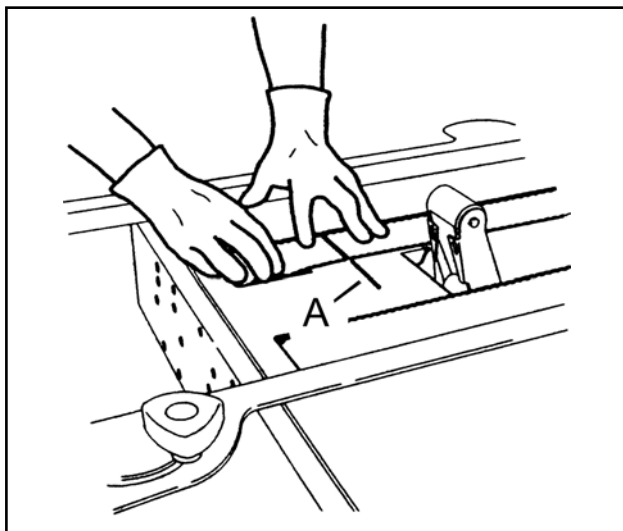

Figure 4-3 – Pull Belt Splicing Pin

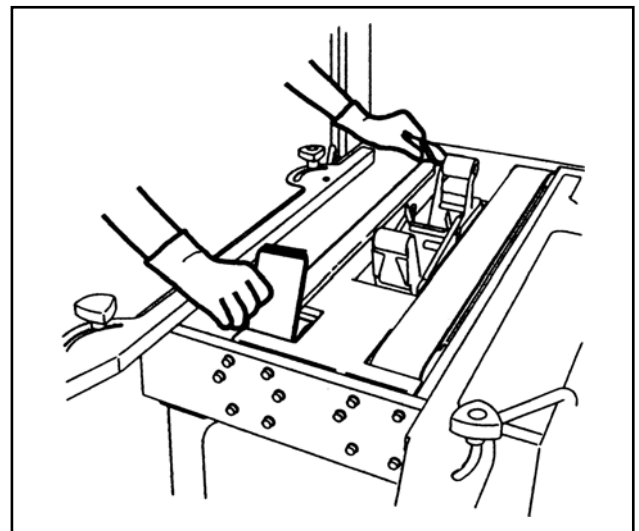

Figure 4-4 – Remove and Replace Belt

## Maintenance (Continued)

### **WARNING**

- **To reduce the risk associated with pinch, entanglement and hazardous voltage:**
  - Turn electrical supply off and disconnect before performing any adjustments, maintenance or servicing the machine or taping heads

#### **Circuit Breaker**

The case sealer is equipped with a circuit breaker which trips if the motors are overloaded. Located inside the electrical enclosure on the side of the machine frame just below the machine bed, the circuit breaker has been pre-set at 2.2 amps and requires no further maintenance.

If circuit is overloaded and circuit breaker trips, unplug machine from electrical power:

#### **Blade Replacement, Taping Head**

See Section II, "Maintenance – Blade Replacement."

### **WARNING**

- **To reduce the risk associated with mechanical and electrical hazards:**
  - Allow only properly trained and qualified personnel to operate and/or service this equipment

1. Determine cause of overload and correct.
2. Remove electrical enclosure cover.
3. Press "Reset" and then press "On" button.  
If circuit breaker will not reset, wait 2 minutes and retry.
4. Replace cover.
5. Plug in machine.
6. Press machine "On" button to resume case sealing.

## Adjustments

### **WARNING**

- **To reduce the risk associated with pinch, entanglement and hazardous voltage:**
  - Turn electrical supply off and disconnect before performing any adjustments, maintenance or servicing the machine or taping heads

### **Box Drive Belt Tension**

The two continuously moving drive belts convey boxes through the tape applying mechanism. The box drive belts are powered by an electric motor.

Tension adjustment of these belts may be required during normal operation. Belt tension must be adequate to positively move the box through the machine and the belts should run fully on the surface of the pulleys at each end of the frame. The idler pulleys on the infeed end are adjusted in or out to provide proper belt tension. Each belt is adjusted separately.

Belt tension is obtained by tightening the adjustment screw so that a moderate pulling force of 3.5 kg [7 lbs.] applied at the midspan, as shown in Figure 5-1, will deflect the belt 25 mm [1 inch]. This will assure positive contact between the belt and the drive pulley on the discharge end of the drive assembly.

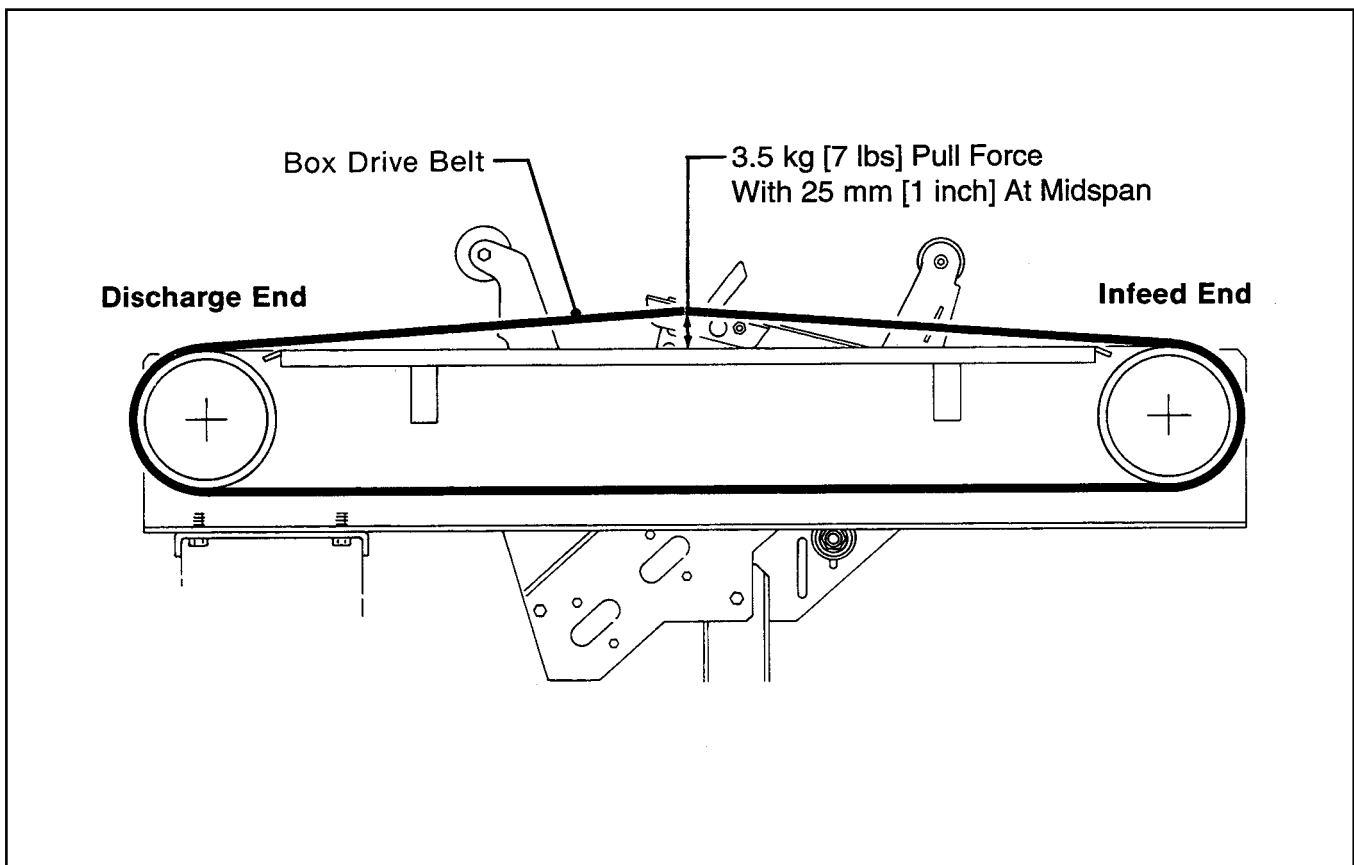

**Figure 5-1 – Box Drive Belt Tension Adjustment**

## Adjustments (Continued)

### WARNING

- To reduce the risk associated with pinch, entanglement and hazardous voltage:
  - Turn electrical supply off and disconnect before performing any adjustments, maintenance or servicing the machine or taping heads

Refer to Figure 5-2 and 5-3 and adjust belt tension as follows:

1. Adjust the tension on the drive belts as needed.
2. Turn the two tension screws in (clockwise) to **increase** tension or out (counterclockwise) to **decrease** tension. Repeat this for both belts as required.

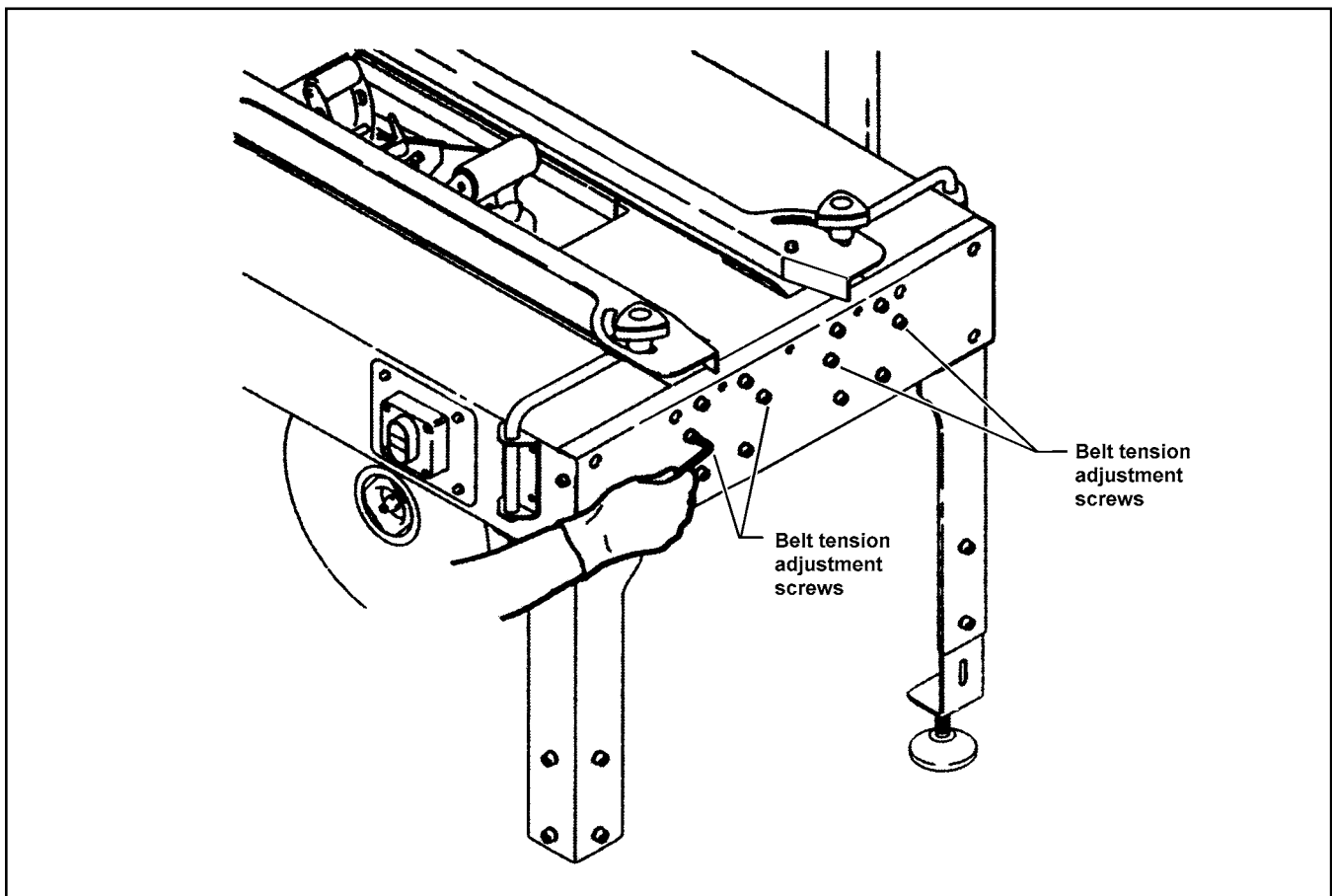

Figure 5-2 - Box Drive Belt Tension Adjustment, (Infeed End)

## Adjustments (Continued)

### **WARNING**

- **To reduce the risk associated with pinch, entanglement and hazardous voltage:**
  - Turn electrical supply off and disconnect before performing any adjustments, maintenance or servicing the machine or taping heads

**Taping Head Adjustments** – Refer to Section II.

### **WARNING**

- **To reduce the risk associated with sharp blade hazards:**
  - Keep hands and fingers away from tape cutoff blades under orange blade guards. The blades are extremely sharp

TAPE WEB ALIGNMENT – Section II

TAPE DRUM FRICTION BRAKE – Section II

APPLYING MECHANISM SPRING – Section II

ONE-WAY TENSION ROLLER – Section II

TAPE LEG LENGTH ADJUSTMENT – Section II

## Special Set-Up Procedure

### **WARNING**

- **To reduce the risk associated with pinch, entanglement and hazardous voltage:**
  - Turn electrical supply off and disconnect before performing any adjustments, maintenance or servicing the machine or taping heads

#### TAPING HEADS

### **WARNING**

- **To reduce the risk associated with sharp blade hazards:**
  - Keep hands and fingers away from tape cutoff blades under orange blade guards. The blades are extremely sharp

1. Remove tape from upper taping head and raise upper assembly to a convenient working height.
2. Loosen the thumbscrews that secure the upper taping head.
3. Hold upper taping head from above the upper assembly, slide head forward and up to remove.

### **WARNING**

- **To reduce the risk associated with muscle strain:**
  - Use proper body mechanics when removing or installing taping heads that are moderately heavy or may be considered awkward to lift

4. Raise upper assembly to provide working room around lower taping head.
5. Lift the lower taping head, shown in Figure 6-3, straight up to remove it from the case sealer bed.
6. Refer to Section II, "Adjustments – Changing Tape Leg Length", for taping head set-up.
7. Replace taping heads reverse of disassembly.

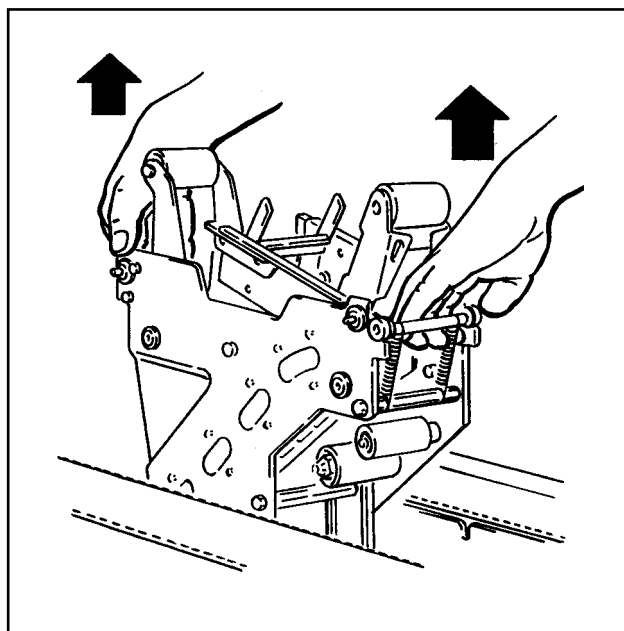

Figure 6-3 – Remove Lower Taping Head

---

## Troubleshooting

---

The Troubleshooting Guide lists some possible machine problems, causes and corrections. Also see Section II "Troubleshooting" for taping head problems.

### Troubleshooting Guide

<b>Problem</b>	<b>Cause</b>	<b>Correction</b>
Drive belts do not convey boxes	Narrow boxes	Check machine specifications. Boxes are narrower than recommended, causing slippage and premature belt wear.
	Worn drive belts	Replace drive belts
	Top taping head does not apply enough pressure	Adjust the box height adjustment using the crank handle
	Top flap compression rollers in too tight	Readjust compression rollers
	Taping head applying spring holder missing	Replace spring holder
Drive belts do not turn	Taping head applying spring set too high	Reduce spring pressure
	Worn or missing friction rings	Replace friction rings
	Drive belt tension too low	Adjust belt tension
	Electrical disconnect	Check power and electrical plug
	Circuit breaker not at correct setting	Set to correct current value
Upper and lower taping head mechanisms interfere with each other	Motor not turning	Evaluate problem and correct
	Machine's minimum height stop does not match tape head leg length setting	Check manual to make sure taping heads match machine setting
Drive belts break	Worn belt	Replace belt
Light boxes tip back on exit	Upper ski down too far	Carefully adjust upper ski
Squeaking noise as boxes pass through machine	Dry compression rollers	Lubricate compression rollers
	Dry column bearings	Lubricate column bearings
	Defective column bearings	Replace column bearings



# Electrical Diagram

## WARNING

- To reduce the risk associated with pinch, entanglement and hazardous voltage:
  - Turn electrical supply off and disconnect before performing any adjustments, maintenance or servicing the machine or taping heads

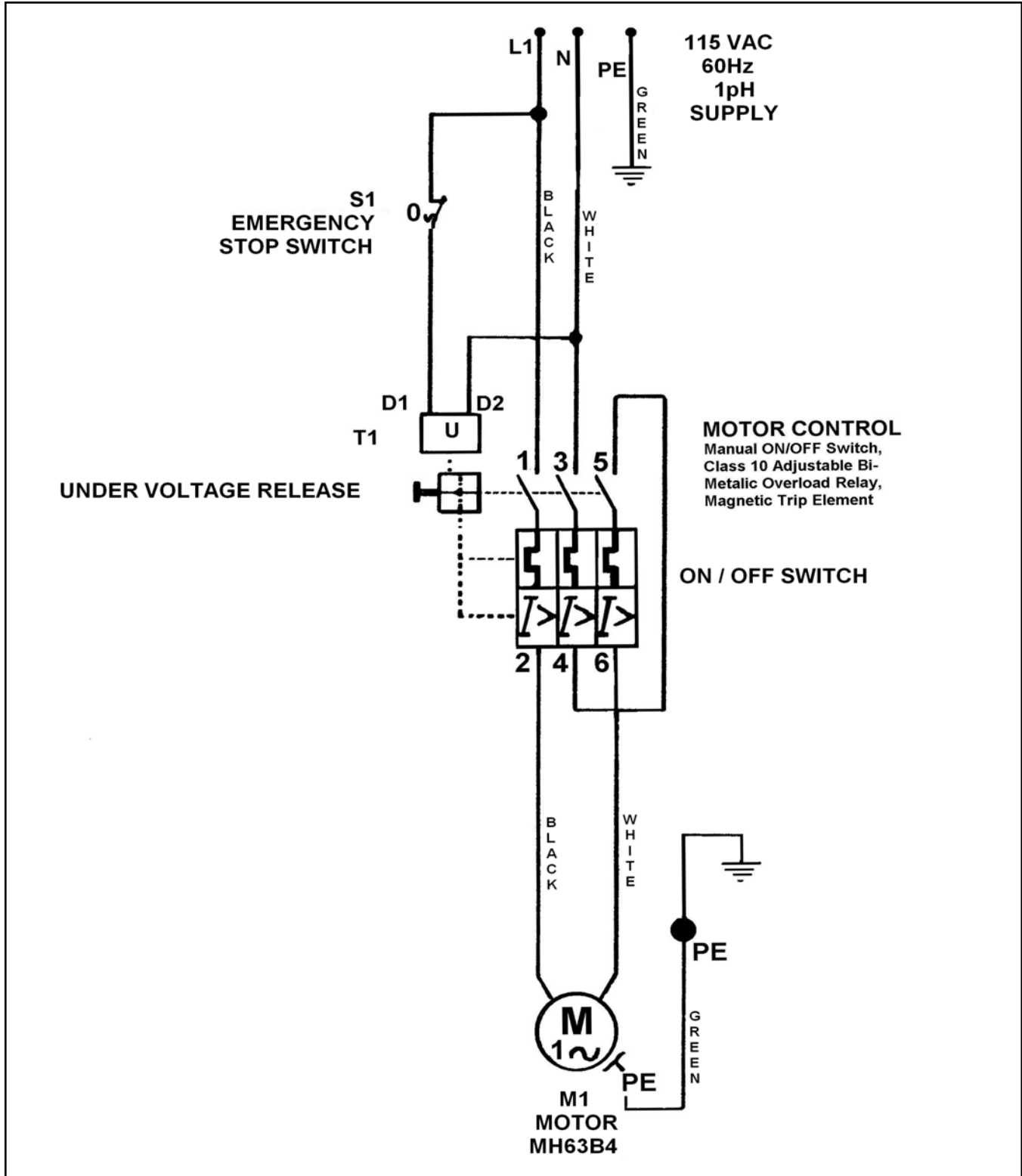

Figure 7-1 Electrical daigram

---

## Replacement Parts And Service Information

---

### Spare Parts

It is suggested that the following spare parts be ordered and kept on hand:

Qty.	Ref. No.	Part Number	Description
4	9455-49	78-8070-1531-4	Belt - Drive W/Pin

---

Also see Section II for recommended taping head spare parts.

### Label Kit

In the event that any labels are damaged or destroyed, **they must be replaced to ensure operator safety.** A label kit, part number 78-8133-9619-5, is available as a stock item. It contains all the safety labels used on the 110a Adjustable Case Sealer.

### Tool Kit

A tool kit, part number 78-8060-8476-6, is available as a stock item. The kit contains the necessary open end and hex socket wrenches for use with the metric fasteners on the case sealer. The threading tool, part number 78-8076-4726-4, contained in above kit is also available as a replacement stock item.

### Replacement Parts Ordering Information and Service

Refer to the first page of this instruction manual "Replacement Parts and Service Information".

---

## Options/Accessories

---

For additional information on the options/accessories listed below, contact your 3M Representative.

<b>Part Number</b>	<b>Option/Accessory</b>
78-8069-3983-7	Caster Kit Attachment
70-0064-0376-3	Conveyor Extension Attachment
70-0064-0353-2	AccuGlide 2+ STD 2 Inch Upper Taping Head, Type 10500
70-0064-0354-0	AccuGlide 2+ STD 2 Inch Lower Taping Head, Type 10500
70-0064-0377-1	Compression Roller Kit

---

## Replacement Parts – Illustrations and Parts Lists

---

### 110a Adjustable Case Sealer, Type 10500 Frame Assemblies

#### To Order Parts:

1. Refer to first illustration, **Frame Assemblies**, for the **Figure Number** that identifies a specific portion of the machine.
2. Refer to the appropriate **Figure or Figures** to determine the parts required and the parts reference number.
3. The Parts List that follows each illustration, includes the **Reference Number, Part Number** and **Part Description** for the parts on that illustration.

***Note** – The complete description has been included for standard fasteners and some commercially available components. This has been done to allow obtaining these standard parts locally, if desired.*

4. Order parts by **Part Number, Part Description** and **Quantity** required. Also include machine name, number and type.
5. Refer to the first page of this instruction manual “**Replacement Parts and Service Information**” for replacement parts ordering information.

**Important** – Not all the parts listed are normally stocked items. Some parts or assemblies shown are available only on special order. Contact 3M/Tape Dispenser Parts to confirm item availability.

# 110a Adjustable Case Sealer

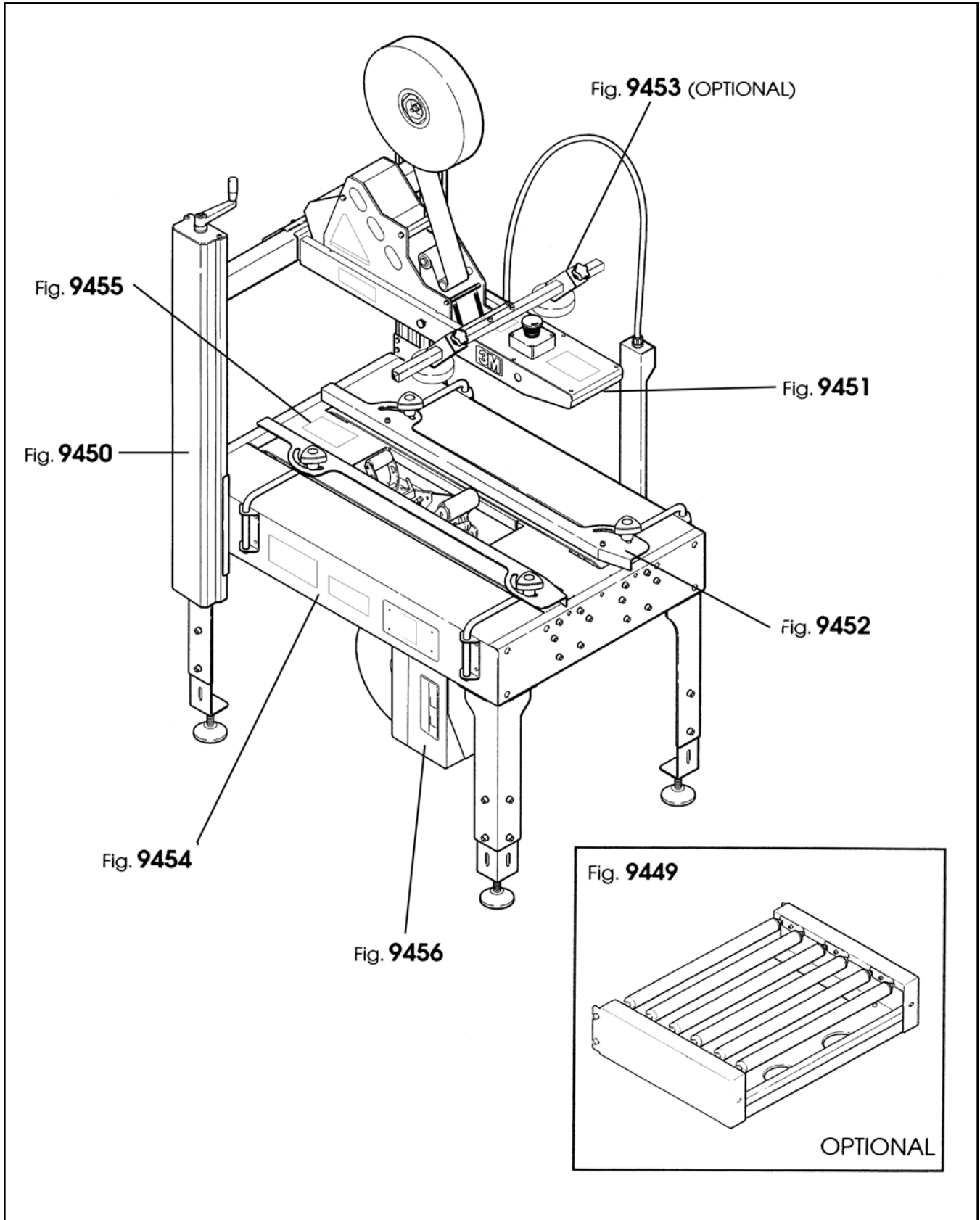

## Frame Assemblies

110a Adjustable Case Sealer

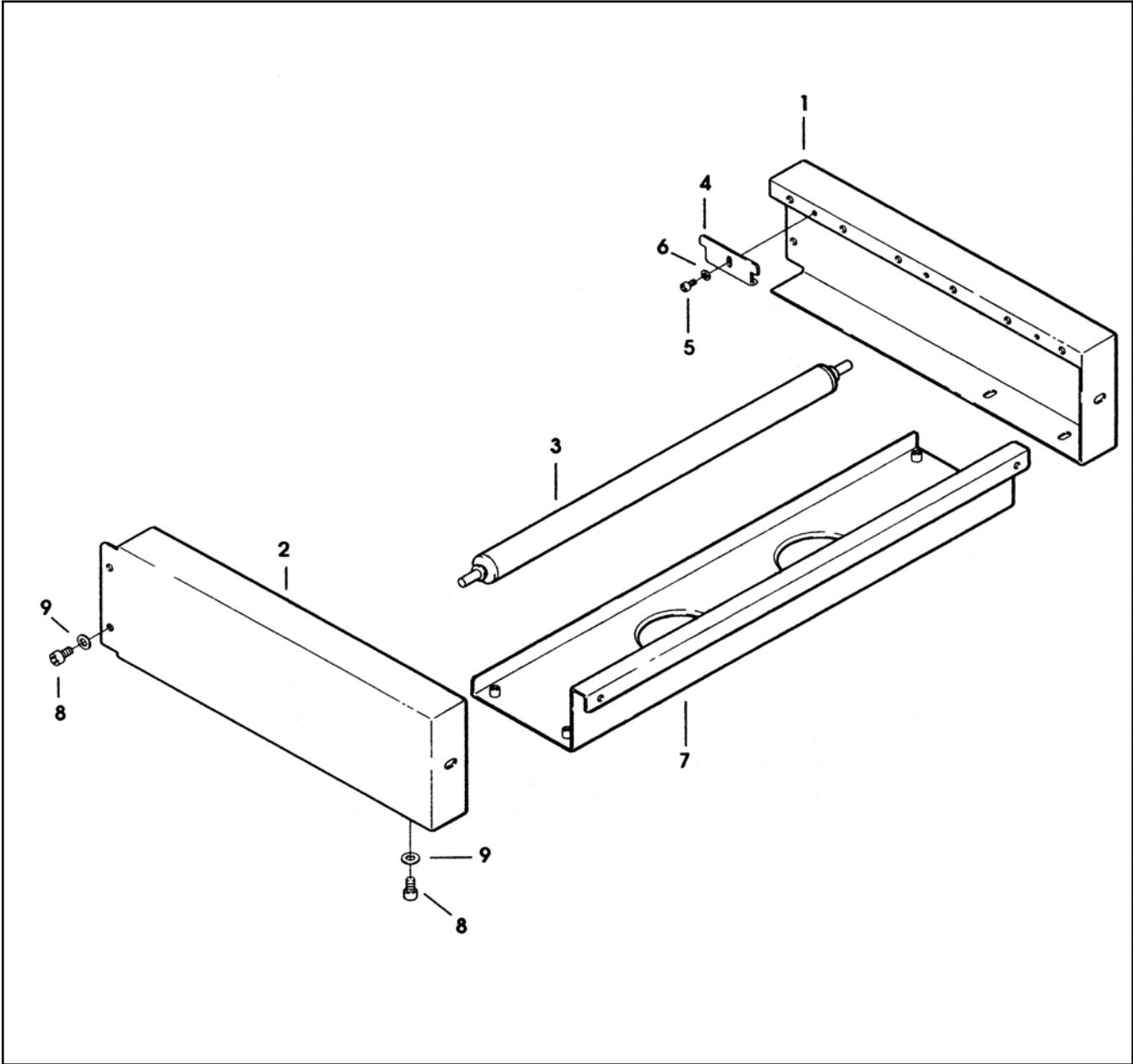

Figure 9449

## Figure 9449

Ref. No.	3M Part No.	Description
9449-1	78-8129-6397-9	Frame – R/H
9449-2	78-8129-6398-7	Frame – L/H
9449-3	78-8076-4579-7	Roller – 32 x 492
9449-4	78-8076-4507-8	Plate - Infeed
9449-5	78-8010-7157-8	Screw - Hex.Hd. M4 x 10
9449-6	78-8005-5740-3	Washer - Flat, M4 Nick.
9449-7	78-8129-6399-5	Reinforcement
9449-8	26-1003-7964-8	Screw - Soc.Hd., M8 x 20
9449-9	78-8017-9318-9	Washer - Flat,M8

# 110a Adjustable Case Sealer

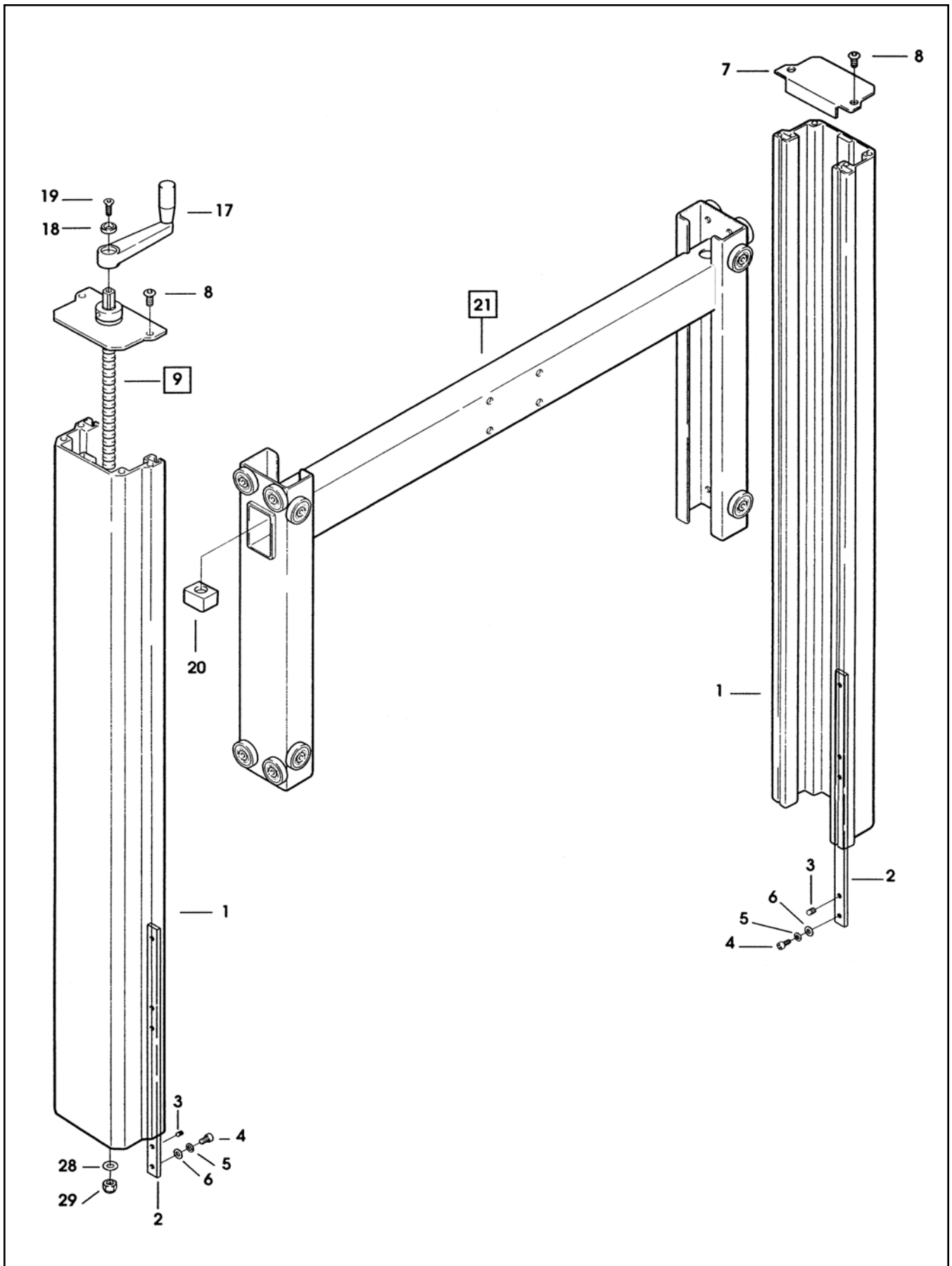

Figure 9450/1



# 110a Adjustable Case Sealer

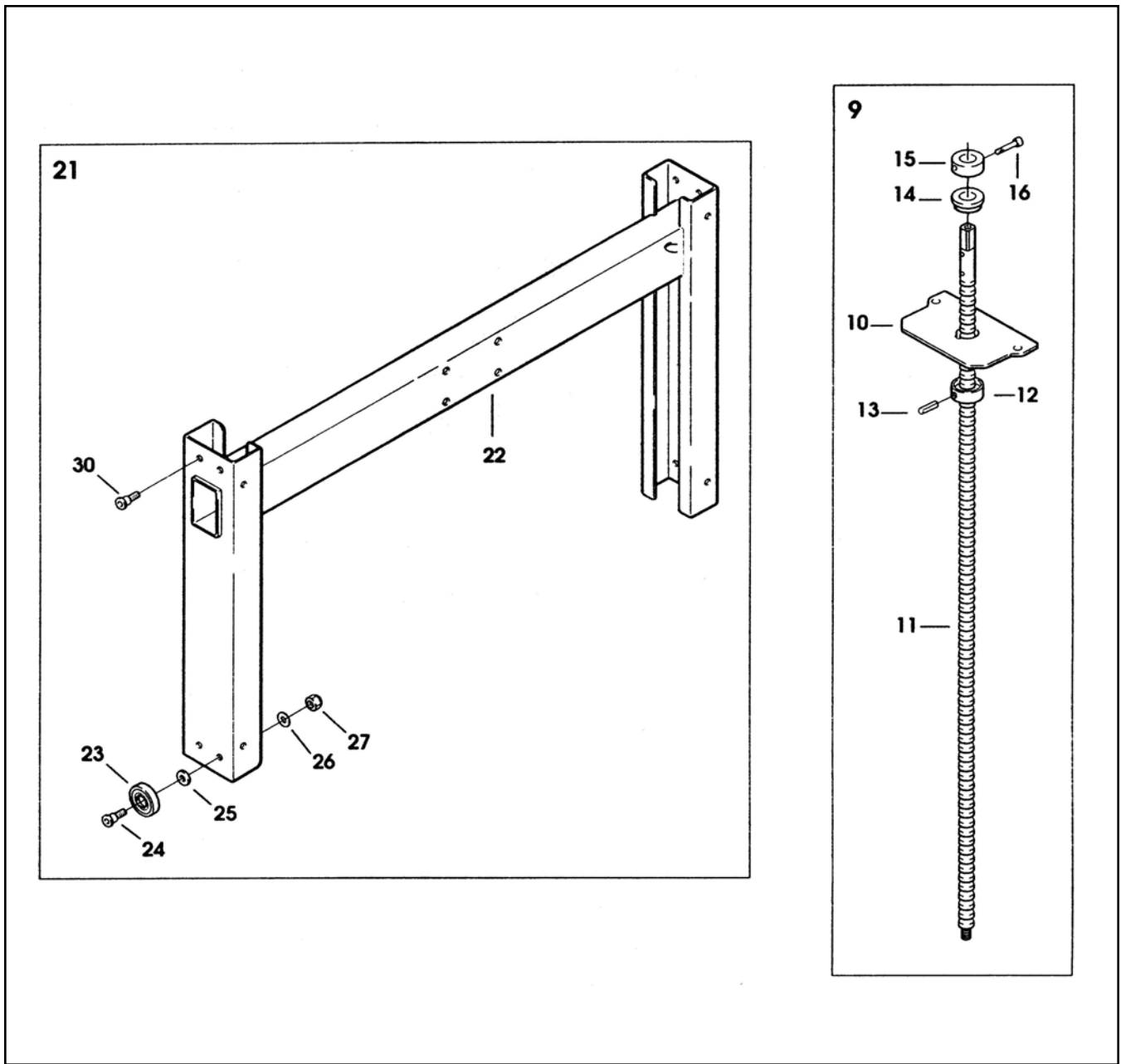

Figure 9450/2

## Figure 9450/1&2

Ref. No.	3M Part No.	Description
9450-1	78-8129-6400-1	Column - Outer
9450-2	78-8129-6401-9	Plate – Column
9450-3	78-8060-7889-1	Set Screw, M8 x 16
9450-4	26-1003-5841-0	Screw - Hex. Hd. M8 x 12
9450-5	78-8005-5736-1	Lockwasher – M8
9450-6	78-8017-9318-9	Washer - Flat, M8
9450-7	78-8129-6402-7	Cover - Column
9450-8	78-8129-6124-7	Screw - Button head, M8 x 16
9450-9	78-8129-6403-5	Assembly - Lead Screw
9450-10	78-8129-6404-3	Cover W/ Hole
9450-11	78-8129-6405-0	Screw - Lead
9450-12	78-8129-6143-7	Bushing
9450-13	78-8054-8586-5	Pin
9450-14	78-8060-8125-9	Bushing
9450-15	78-8129-6142-9	Nut
9450-16	26-1003-7946-5	Screw - Soc.Hd., M4 x 25
9450-17	78-8129-6118-9	Handle - Height Adjustment
9450-18	78-8060-8073-1	Washer – Flat, (Motor)
9450-19	26-0001-5862-1	Screw - Flat Soc. Hd., M5 x 12
9450-20	78-8054-8571-7	Nut - Plastic
9450-21	78-8129-6406-8	Assembly - Inner Column
9450-22	78-8129-6407-6	Column - Inner
9450-23	78-8129-6147-8	Bearing – Ball
9450-24	78-8017-9106-8	Screw-Bearing Shoulder
9450-25	78-8054-8942-0	Washer - Flat
9450-26	26-1000-0010-3	Washer – Flat, M6
9450-27	26-1003-6916-9	Nut - Locking, M6
9450-28	26-1004-5507-5	Washer - Flat, M8
9450-29	26-1003-6904-5	Nut - Hex. M8
9450-30	78-8054-8589-9	Screw – Special

110a Adjustable Case Sealer

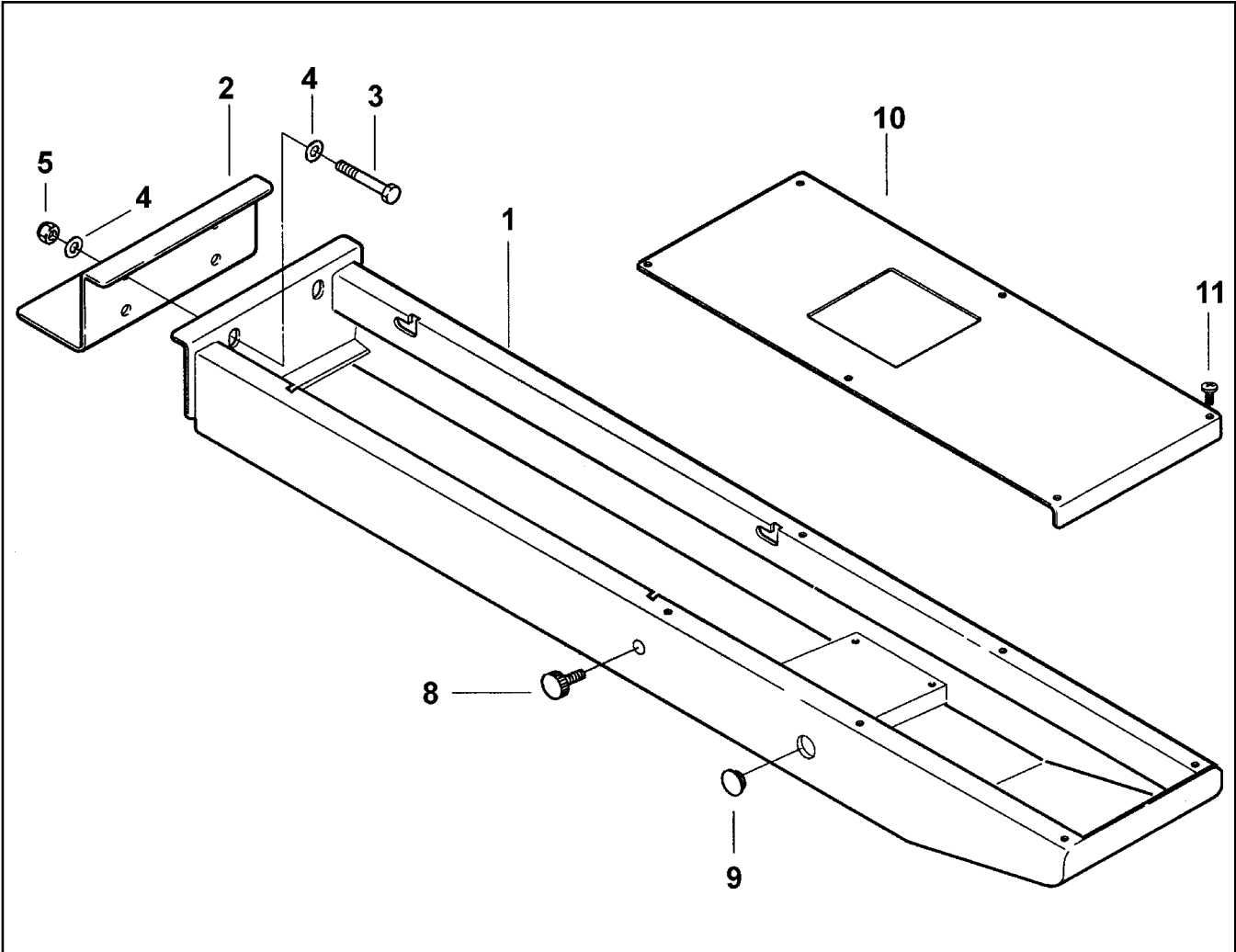

Figure 9451

## Figure 9451

Ref. No.	3M Part No.	Description
9451-1	78-8133-9242-6	Support - Upper Head W/Insert
9451-2	78-8133-9243-4	Bracket - Upper Unit
9451-3	26-1002-5949-3	Screw – Hex. Hd., M8 x 60
9451-4	78-8017-9318-9	Washer – Flat, M8
9451-5	78-8017-9313-0	Nut - Locking, M8 Nick.
9451-8	78-8070-1555-3	Block - Upper Head
9451-9	78-8076-4744-7	Plug 20 x 1,5 (Hole / 17)
9451-10	78-8133-9244-2	Plate - Cover
9451-11	78-8017-9066-4	Screw - Pan Hd., M5 x 12

# 110a Adjustable Case Sealer

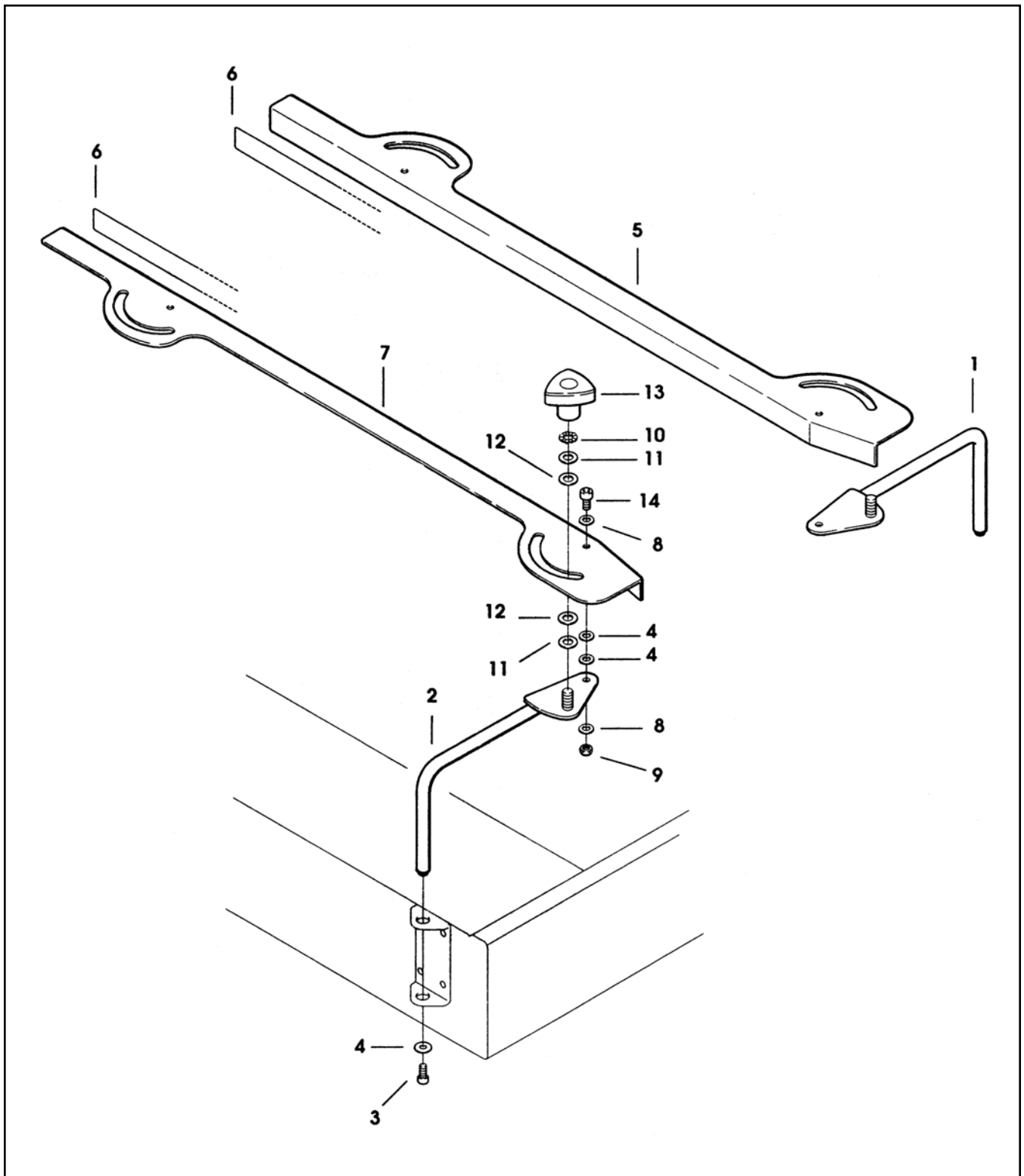

Figure 9452

## Figure 9452

Ref. No.	3M Part No.	Description
9452-1	78-8129-6410-0	Lever-R/H
9452-2	78-8129-6411-8	Lever-L/H
9452-3	26-1003-7957-2	Screw – Soc. Hd., M6 x 16
9452-4	78-8042-2919-9	Washer – Triple, M6
9452-5	78-8129-6412-6	Guide - R/H
9452-6	78-8079-5378-7	Tape - Guide
9452-7	78-8129-6413-4	Guide - L/H
9452-8	26-1000-0010-3	Washer - Flat, M6
9452-9	78-8091-0418-1	Nut - Locking, M6
9452-10	78-8057-5803-0	Washer - Dented
9452-11	26-1004-5510-9	Washer - Flat, M10
9452-12	78-8017-9074-8	Washer - Nylon M15
9452-13	78-8070-1549-6	Knob, VTR-B-M10
9452-14	78-8010-7210-5	Screw – Soc. Hd., M6 x 20

# 110a Adjustable Case Sealer

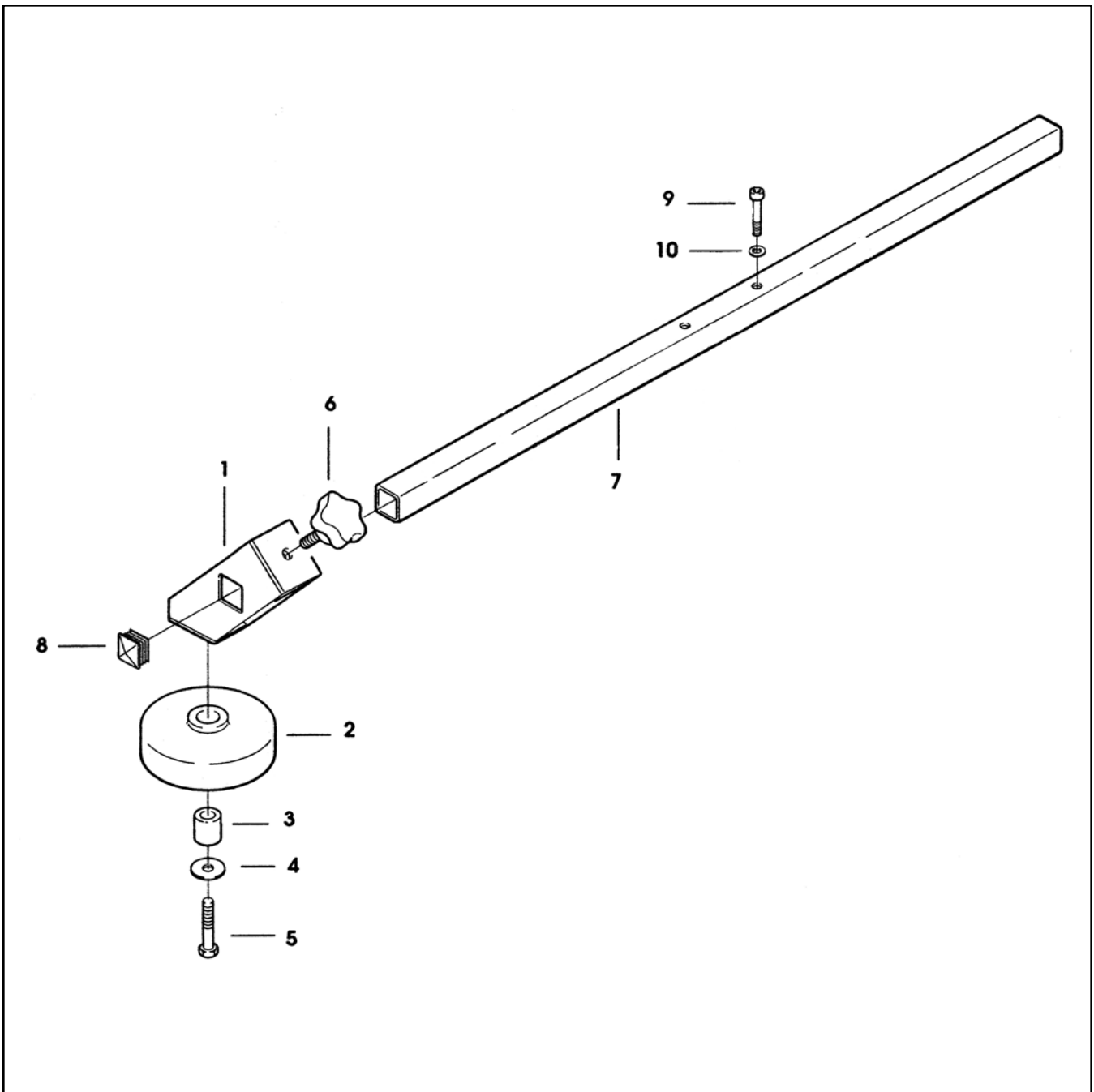

Figure 9453

## Figure 9453

Ref. No.	3M Part No.	Description
9453-1	78-8129-6414-2	Support - Roller
9453-2	78-8054-8648-3	Roller - Pressure
9453-3	78-8055-0622-3	Bushing
9453-4	78-8052-6703-2	Washer – Special
9453-5	26-1003-5845-1	Screw - Hex Hd., M8 x 40
9453-6	78-8129-6155-1	Knob
9453-7	78-8129-6415-9	Tube - Roller Support
9453-8	78-8052-6652-1	Cap - End
9453-9	26-1003-7962-2	Screw - Soc. Hd., M6 x 40
9453-10	78-8042-2919-9	Washer - Triple, M6



# 110a Adjustable Case Sealer

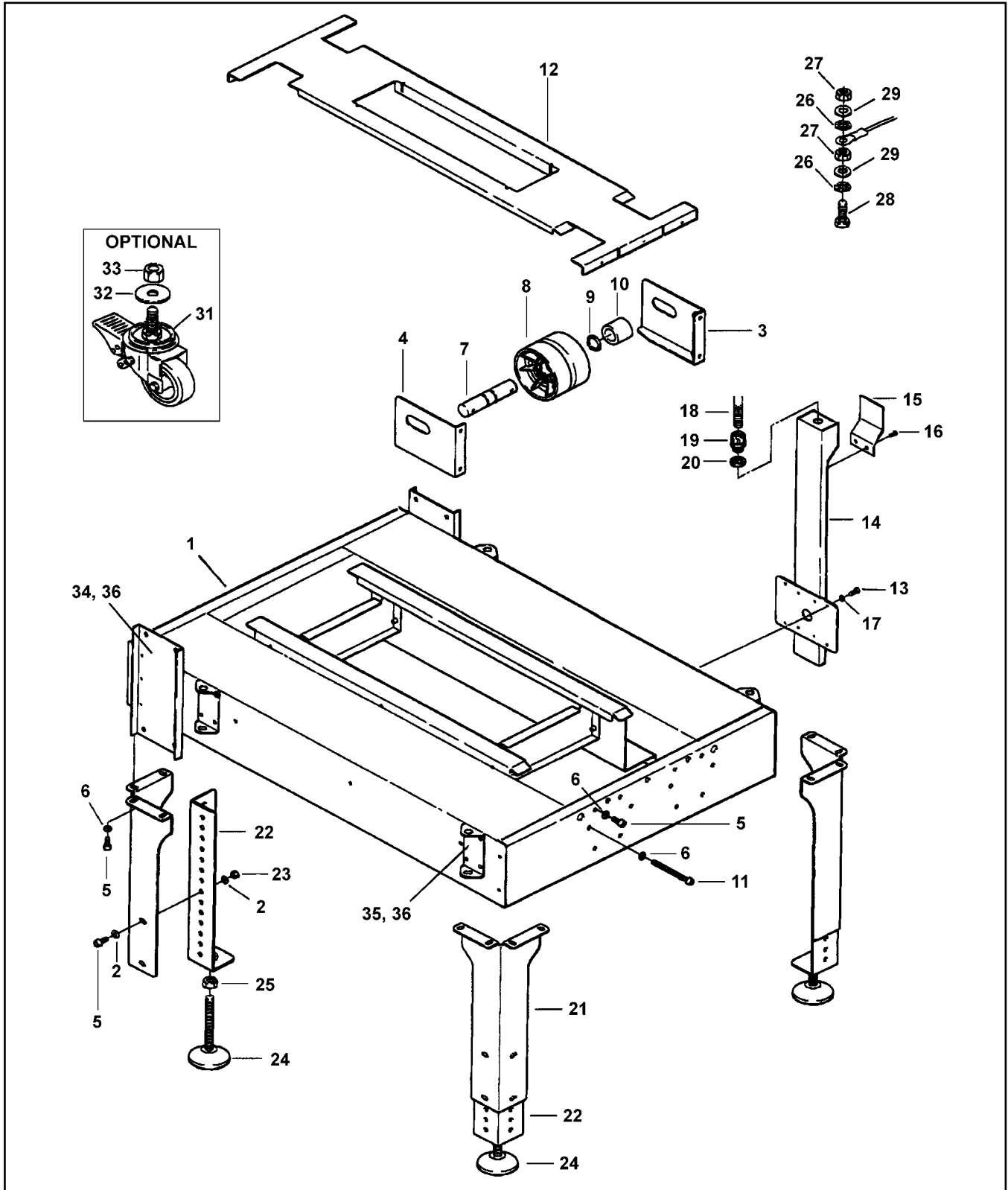

Figure 9454

## Figure 9454

Ref. No.	3M Part No.	Description
9454-1	78-8133-9252-5	Frame, W/Insert
9454-2	26-1004-5507-5	Washer - Flat, M8
9454-3	78-8129-6420-9	Bracket - R/H
9454-4	78-8129-6421-7	Bracket - L/H
9454-5	26-1003-7964-8	Screw - Soc. Hd., M8X20
9454-6	78-8017-9318-9	Washer- Flat, M8
9454-7	78-8129-6422-5	Shaft Pulley
9454-8	78-8052-6710-7	Roller-Idler
9454-9	12-7997-0272-0	E-Ring, M25
9454-10	78-8129-6423-3	Spacer
9454-11	78-8129-6424-1	Screw - Special, M8 x 100
9454-12	78-8129-6426-6	Conveyor
9454-13	78-8032-0382-3	Screw - Soc. Hd., M5 x 16, Zinc
9454-14	78-8129-6427-4	Housing - Wire
9454-15	78-8129-6428-2	Cover
9454-16	78-8129-6103-1	Screw - Special, M4 x 10
9454-17	78-8005-5741-1	Washer - Flat, M5
9454-18	78-8129-6108-0	Sleeve - Wire
9454-19	78-8129-6429-0	Union - Straight
9454-20	78-8129-6430-8	Nut - Plastic, M16 x 1.5
9454-21	78-8129-6431-6	Leg - Outer
9454-22	78-8129-6432-4	Assembly - Inner Leg
9454-23	26-1003-6904-5	Nut - Hex, M8
9454-24	78-8129-6433-2	Foot - Leveling
9454-25	26-1003-6906-0	Nut - Hex., M12
9454-26	78-8076-4716-5	Washer - Star, M4
9454-27	78-8010-7416-8	Nut - Hex., M4
9454-28	78-8091-0538-6	Screw - Hex.Hd., M4 x 20
9454-29	78-8005-5740-3	Washer - Flat, M4
9454-31	26-1009-9096-4	Caster W/Brake
9454-32	26-1009-9094-9	Washer - Locking, M12
9454-33	26-1003-9095-6	Nut - Hex., M12
9454-34	78-8133-9253-3	Plate - Column Support/Mounting
9454-35	78-8133-9254-1	Support - Centering Guide
9454-36	78-8133-9255-9	Rivet

# 110a Adjustable Case Sealer

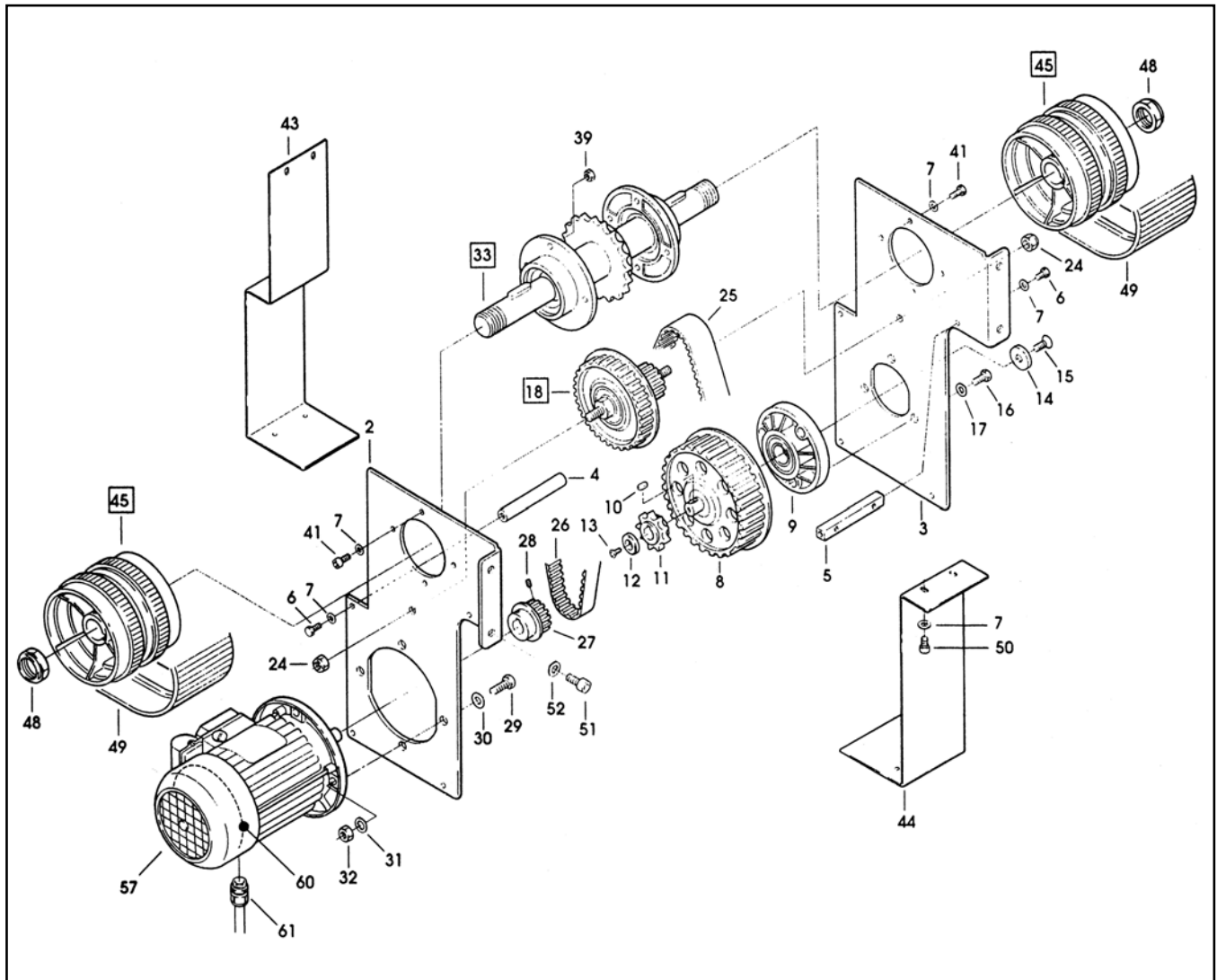

Figure 9455/1

# 110a Adjustable Case Sealer

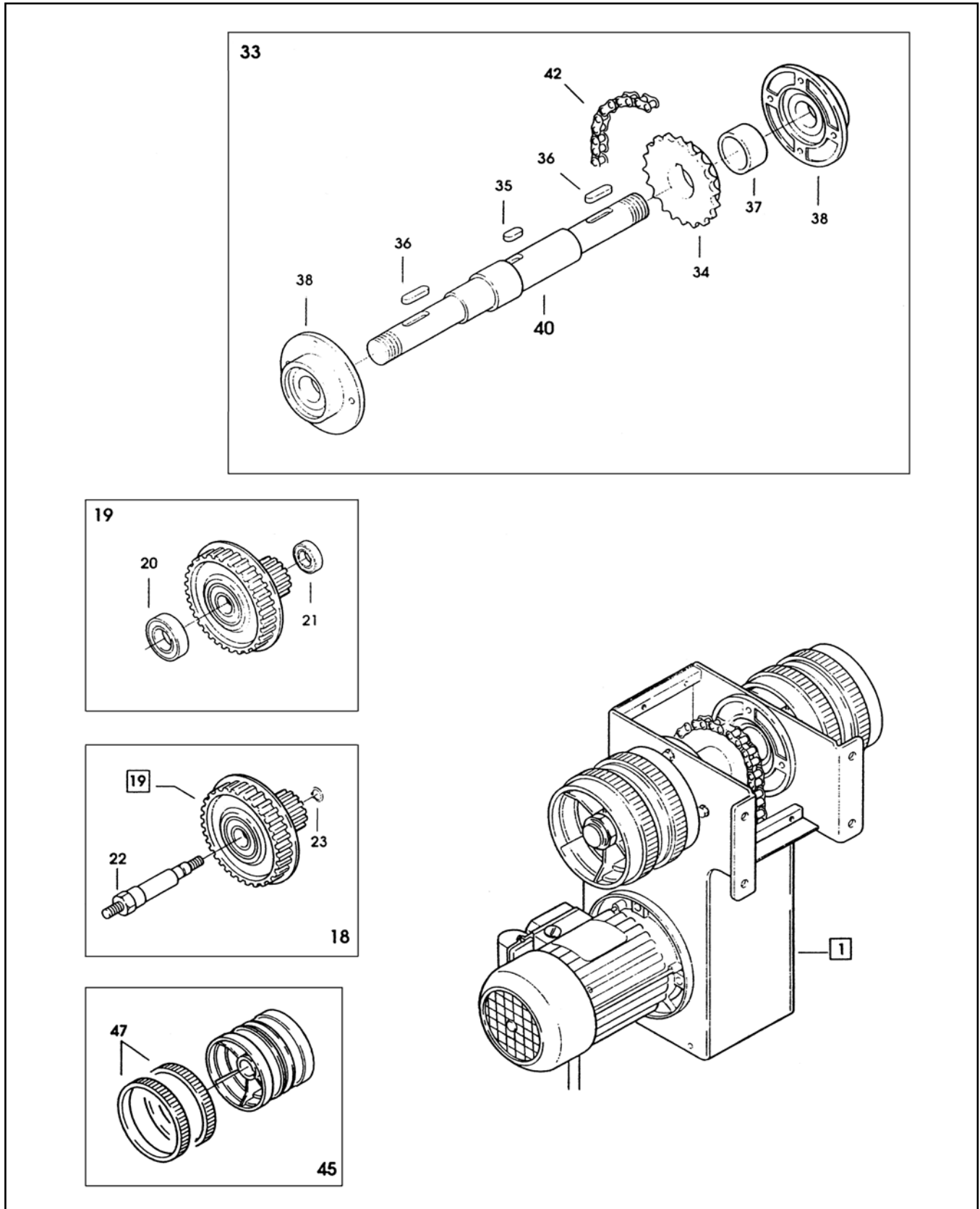

Figure 9455/2

## Figure 9455/1 & 2

Ref. No.	3M Part No.	Description
9455-1	78-8129-6437-3	Gearbox Assy, W/O Motor
9455-2	78-8129-6438-1	Frame - R/H. Gearbox
9455-3	78-8129-6439-9	Frame - L/H. Gearbox
9455-4	78-8054-8975-0	Spacer
9455-5	78-8054-8977-6	Spacer
9455-6	26-1003-5820-4	Screw - Hex Hd., M5 x 12
9455-7	78-8005-5741-1	Washer - Flat, M5
9455-8	78-8060-8146-5	Assembly - Gear Box Pulley
9455-9	78-8054-8979-2	Housing - Bearing
9455-10	78-8028-8244-5	Key - 4 x 4 x 10mm
9455-11	78-8054-8981-8	Sprocket - 3/8 Pitch, 11 Teeth
9455-12	78-8054-8877-8	Washer, 5,5/20 x 4
9455-13	26-0001-5862-1	Screw - Flat Soc.Hd., M5 x 12
9455-14	78-8054-8577-4	Washer - Special
9455-15	26-1001-9843-6	Screw - Flat Soc.Hd.,M6 x 16
9455-16	78-8010-7193-3	Screw - Hex. Hd., M6 x 20
9455-17	78-8042-2919-9	Washer - Triple, M6
9455-18	78-8076-4530-0	Assembly - Pulley
9455-19	78-8129-6440-7	Assembly - Pulley
9455-20	78-8023-2544-5	Bearing - 6203-2RS
9455-21	78-8023-2410-9	Bearing - 6000-2RS
9455-22	78-8076-4531-8	Shaft - Timing Pulley
9455-23	78-8016-5855-6	E - Ring, 10mm
9455-24	78-8076-4580-5	Nut - Locking, M8
9455-25	78-8057-5808-9	Belt - Timing, 187L100
9455-26	78-8057-5724-8	Belt - Timing, 187L050,
9455-27	78-8054-8982-6	Pulley - Timing, 11 Teeth
9455-28	26-1003-8816-9	Screw - Set, M5 x 6
9455-29	78-8017-9301-5	Screw - Hex. Hd., M8 x 25
9455-30	26-1004-5507-5	Washer - Flat, M8

(continued on next page)

## Figure 9455/1 & 2 (continued)

Ref. No.	3M Part No.	Description
9455-31	78-8005-5736-1	Lockwasher, M8
9455-32	26-1003-6904-5	Nut - Hex., M8
9455-33	78-8076-4582-1	Assembly - Drive Shaft
9455-34	78-8054-8986-7	Sprocket - 3/8" Pitch, 28 Teeth
9455-35	78-8057-5811-3	Key - 6 x 6 x 20mm.
9455-36	78-8057-5739-6	Key - M5 x 5 x 30mm
9455-37	78-8054-8984-2	Bushing
9455-38	78-8054-8983-4	Housing - Bearing
9455-39	78-8010-7417-6	Nut - Hex., M5
9455-40	78-8076-4581-3	Shaft - Gear Box
9455-41	78-8032-0382-3	Screw - Soc. Hd., M5 x 16 Zinc
9455-42	78-8054-8987-5	Chain - 3/8 Pitch, 57 Pitch Lg.
9455-43	78-8129-6442-3	Cover - Front
9455-44	78-8129-6441-5	Cover - Rear
9455-45	78-8076-5105-0	Assembly - Drive Pulley
9455-47	78-8052-6713-1	Ring - Polyurethane
9455-48	78-8060-8416-2	Nut - Special, M20 x 1
9455-49	78-8070-1531-4	Belt - Drive, With Pin
9455-50	26-1003-7949-9	Screw - Soc. Hd., M5 x 12
9455-51	26-1003-7964-8	Screw - Soc. Hd., M8 x 20
9455-52	78-8017-9318-9	Washer - Flat, M8
9455-57	78-8046-8267-8	Motor- 110/110V. 50/60HZ 1-Phase. 0.13 KW
9455-60	78-8076-5372-6	Fan - Motor
9455-61	78-8076-4532-6	Grip - Cord

# 110a Adjustable Case Sealer

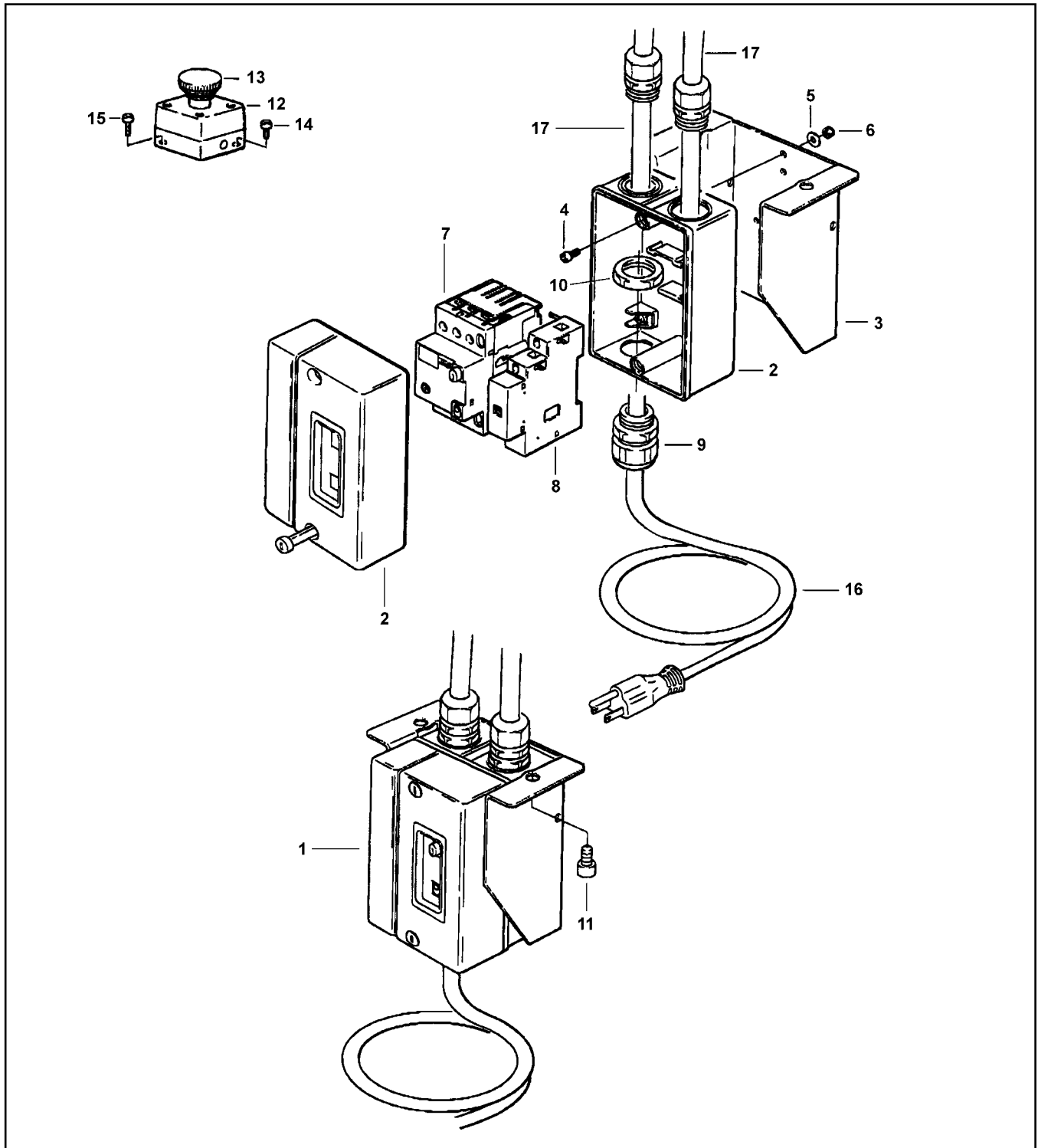

Figure 9456

## Figure 9456

Ref. No.	3M Part No.	Description
9456-1	78-8133-9250-9	Assembly - Switch, 100V/115V 50/60 HZ MFF SM1-P (A.B.)
9456-2	78-8100-1173-0	Box - Switch, Allen Bradley
9456-3	78-8133-9251-7	Support - On/Off Switch
9456-4	26-1003-7945-7	Screw - Soc. Hd., M4 x 20
9456-5	78-8017-9018-5	Washer - Flat, Special, M4
9456-6	26-1003-6914-4	Nut - Locking, M4
9456-7	78-8100-0755-5	Switch - Thermal, Allen Bradley 2.5 - 4
9456-8	78-8100-1175-5	Coil - Under Voltage, 110V, Allen Bradley
9456-9	78-8057-5807-1	Grip - Cord, Skintop St 16
9456-10	78-8100-1202-7	Nut - Locking, GMP16
9456-11	26-1003-7963-0	Screw - Soc. Hd., M8 x 16 Zinc
9456-12	78-8076-5194-4	Box - E-Stop, Yellow, Allen Bradley
9456-13	78-8094-6385-0	Switch - E-Stop /60 800EP-MTS643LX01
9456-14	26-1003-7943-2	Screw - Soc. Hd., M4 x 12 Zinc
9456-15	78-8094-6381-9	Screw - Soc. Hd., M4 x 15 Zinc
9456-16	78-8028-7909-4	Cord - Power
9456-17	78-8060-8053-3	Wire - 3-Pole, 5 Meters Length